

Panasonic

900MHz Cordless Answering System

Model No. **KX-TC1868B**
KX-TC1871B
KX-TC1872B

Pulse-or-tone dialing capability

Operating Instructions



KX-TC1871B

Caller ID Compatible

PLEASE READ BEFORE USE AND SAVE.

Charge the battery for about 6 hours before initial use.

Panasonic World Wide Web address: <http://www.panasonic.com>
for customers in the USA or Puerto Rico

Preparation

Cordless Telephone

Answering System

Useful Information

Before Initial Use

Please read **IMPORTANT SAFETY INSTRUCTIONS** on page 88 before use.
Read and understand all instructions.

Thank you for purchasing your new Panasonic cordless telephone.

Caller ID and Call Waiting Service, where available, are telephone company services. After subscribing to Caller ID, this phone will display a caller's name and phone number. Call Waiting Caller ID, which displays a second caller's name and phone number while the user is on another call, requires a subscription to both Caller ID and Call Waiting.

Attach your purchase receipt here.

For your future reference

Serial No. _____
(found on the bottom of the unit)

Date of purchase _____

Name and address of dealer _____

Accessories (included)

For headset information for the KX-TC1868B cordless phone and extra orders, call 1-800-332-5368.

AC Adaptor (p. 13)
Order No.
PQLV1Z

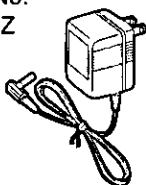

one

Telephone Line
Cord (p. 13)



one

Battery (p. 14)
Order No.
P-P508



one

Handset Cover
(p. 14)
Order No.
PQKK10099Z1



one

Wall Mounting
Adaptor (p. 78)
Order No.
PQKL10035Z1

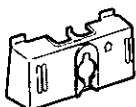

one

Handset
Holder (p. 78)
Order No.
PQKE10097Z1



one

Belt Clip
(p. 80)
Order No.
PQKE10098Z1



one

For Best Performance

Battery Charge

A rechargeable Ni-Cd battery powers the handset. Charge the battery for about **6 hours** before initial use (p. 14).

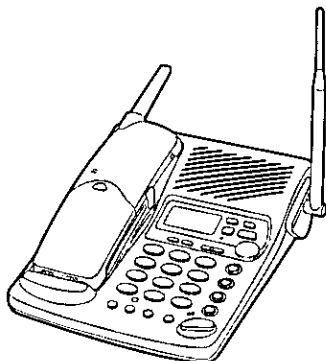

Base Unit Location/Noise

Calls are transmitted between the base unit and the handset using wireless radio waves. **For maximum distance and noise-free operation**, the recommended base unit location is:

Away from electrical appliances such as a TV, personal computer or another cordless phone.

In a **HIGH** and **CENTRAL** location with no obstructions such as walls.

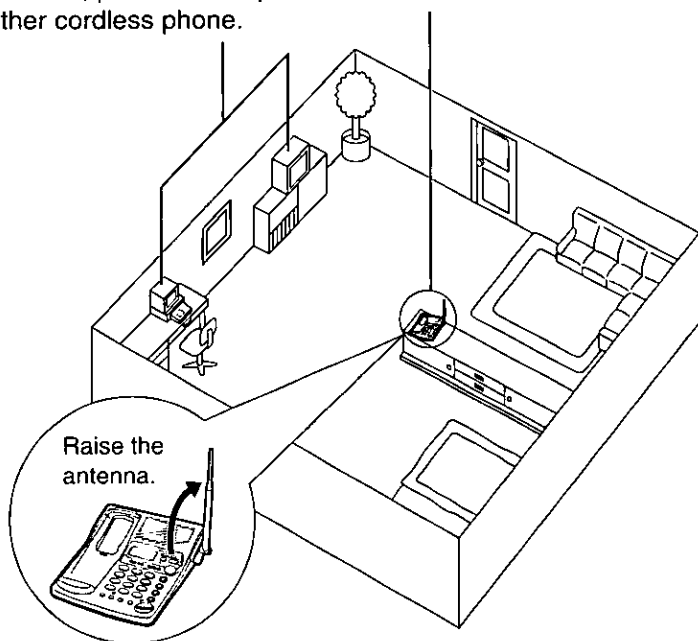

- If more than one cordless phone is being used and your handset is near another cordless phone's base unit, noise may be heard. Move away from the other cordless phone's base unit and closer to your base unit.

Contents

Preparation

Location of Controls	6
Displays	9
Settings	13
Connections	13
Installing the Battery in the Handset	14
Battery Charge	14
Selecting the Dialing Mode	16
Selecting the Line Mode	17
Programmable Functions	18
Setting the Auto Talk Feature	19
Selecting the Ringer Volume	20
Preparing the Answering System	21
Greeting Message	21
Programming Summary for the Answering System	23
Day and Time Adjustment	24
Selecting the Caller's Recording Time	26
Selecting the Number of Rings	27

Cordless Telephone

Making Calls	28
With the Handset	28
With the Base Unit	30
Simultaneous Keypad Dialing	32
Answering Calls	33
With the Handset	33
With the Base Unit	33
Caller ID Service	34
Using the Caller List	36
Viewing the Caller List	36
Calling Back from the Caller List	37
Editing the Caller's Phone Number	38
Storing Caller List Information in the Directory	40
Erasing Caller List Information	41
One-Touch Dialer	43
Storing a Phone Number in the DIRECT Button	43
Dialing the Stored Number in the DIRECT Button	44
Using the Directory	45
Storing Names and Numbers in the Directory	45
Steps for Entering Names and Symbols	47

Finding Items in the Directory	49
Dialing from the Directory	51
Editing an Item in the Directory	52
Erasing an Item from the Directory	53
Intercom	54
Transferring a Call Using the Intercom	55
Special Features	56
Automatic Security Code Setting	56
Temporary Tone Dialing (For Rotary or Pulse Service Users)	56
For Call Waiting Service Users	57
How to Use the PAUSE Button (For Analog PBX Line/Long Distance Service Users)	57
FLASH Button	58

Preparation

Cordless Telephone

Answering System

Useful Information

Answering System

Automatic Answering Operation	59
Setting the Unit to Answer Calls	59
Listening to Messages	60
From the Handset	62
Erasing Messages	63
Pager Call	64
Storing a Pager Number	64
Storing Your Home Telephone Number	66
Pager Mode Setting	68
Setting the Unit to Call a Pager	69
Remote Operation from a Touch Tone Phone	70
Setting the Remote Code	71
Voice Menu	72
Direct Remote Operation	74
Remote Operation with the Handset	76

Useful Information

Wall Mounting	78
Using the Belt Clip	80
Using the Headset	80
Battery Replacement	82
Adding Another Phone	82
Before Requesting Help	83
Important Safety Instructions	88
FCC and Other Information	90

Location of Controls

Base unit

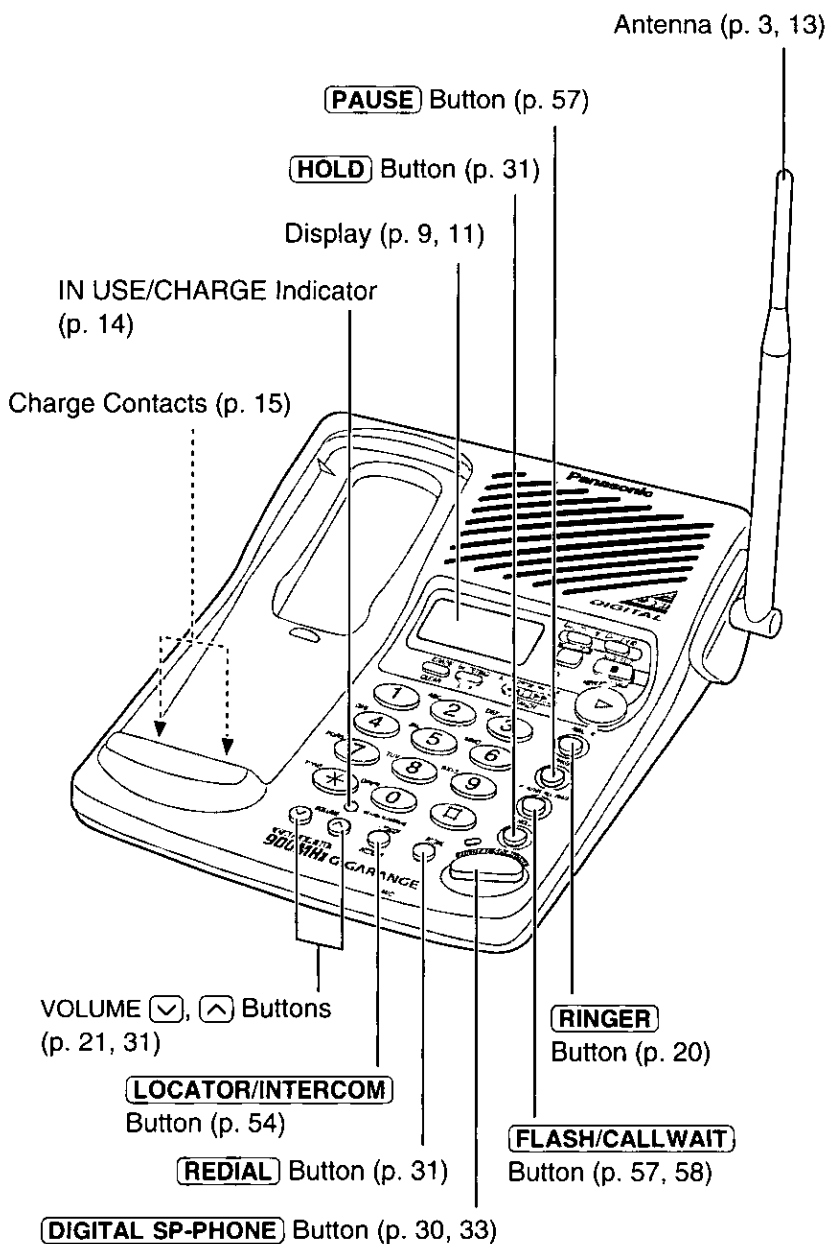

CALLER ID Button (p. 36)

DIRECTORY Button (p. 50)

SKIP/FF Button (p. 36, 50, 61)

REPEAT/REW Button (p. 36, 50, 61)

GREETING/EDIT Button (p. 21, 39)

ERASE/CLEAR Button (p. 22, 41, 63)

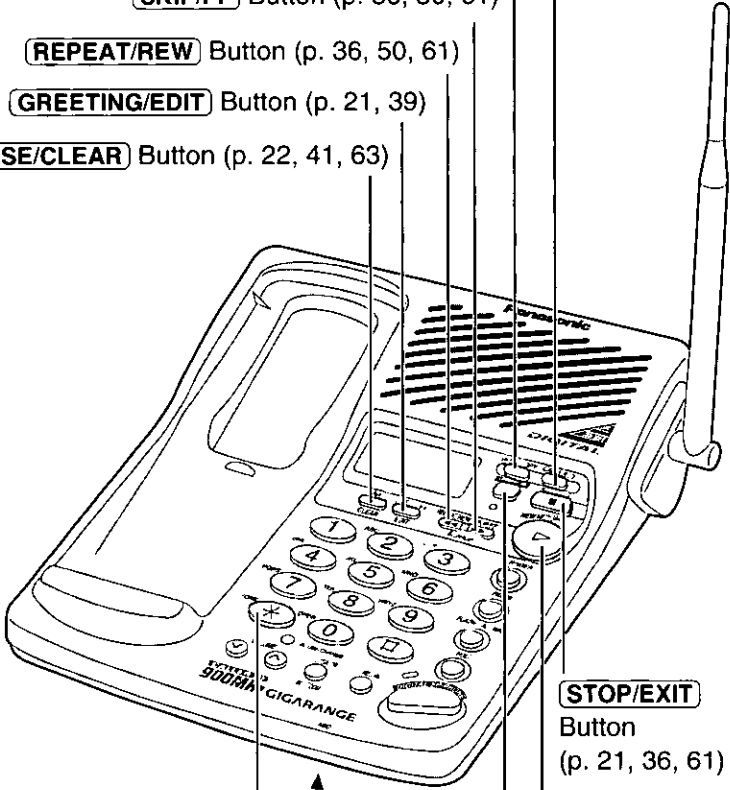

STOP/EXIT

Button
(p. 21, 36, 61)

NEW MESSAGE

Button (p. 60)

TONE Button (p. 56)

ANSWER ON Button and Indicator

(p. 59, 60, 63)

MIC (Microphone) (p. 21, 30, 54)

► Location of Controls

Handset

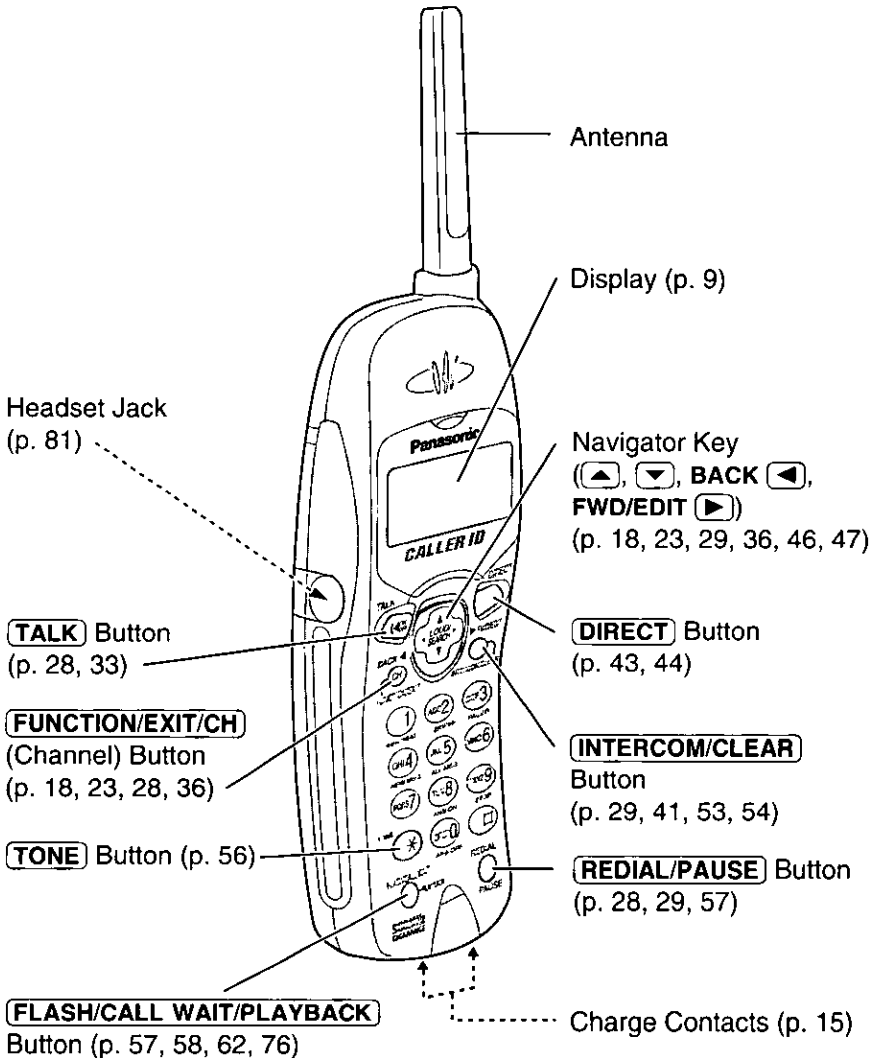

Displays



Both the handset and the base unit show you instructions and information on the displays. These display prompts are shown below.

Common prompts for the handset and the base unit

No items stored

The Caller List is empty or there are no stored items in the directory.

TINA ROBINSON
1-000-222-3333

When a call is received, the display shows the caller's name and number after the first ring.

JACK SMITH
1-222-333-4444
11:20A JAN.12 x3

This is a name from the Caller List.

The display shows:

- the caller's name,
- the caller's number,
- the time and date of the last call (ex. Jan. 12, 11:20 AM), and
- the number of times called (ex. 3 times).

Ann 
1234567890

This is a name from the directory. The stored name and phone number are displayed.

NANCY BROWN
1-000-222-333
----Waiting-----

A second call is received during a conversation (p. 57).

Handset only

Recharge battery 

The battery needs to be charged. Place the handset on the base unit to charge the battery (p. 14).

(continued )

► Displays

12 new calls
[■■■■]

The display shows the number of new calls and the battery strength (p. 14) while the handset is on the base unit.

12 new calls
▼▲ ▶=Directory

The display shows the number of new calls when ▼ or ▲ is pressed while the handset is off the base unit.

To search from the most recent call, press ▼.
To search from the oldest call, press ▲ (p. 36).
To go to the directory list, press **FWD/EDIT** ► (Directory key).

Talk
01-06-35 [■■■■]

During a conversation, the display shows the length of the call (ex. 1 hour, 6 minutes and 35 seconds). The battery strength is also displayed (p. 14).

No link to base.
Place on cradle
and try again.

The handset has lost communication with the base unit. Place the handset on the base unit and try again.

Please lift up
and try again

▼, ▲, **BACK** ◀ or **FWD/EDIT** ► was pressed while the handset was on the base unit. Lift the handset and press the button again.

⋄ Ringer off ⋄

When the ringer volume is set to OFF (p. 20), "Ringer off" will flash for about 45 seconds before the unit returns to the standby mode (p. 15).

Directory full

When trying to store an item or Caller List information in the directory, the directory memory is full (p. 40, 46).

Not available

▼, ▲, **BACK** ◀ or **FWD/EDIT** ► was pressed while the base unit was not in the standby mode.

Answering
system setting.
See base unit.

The unit is in answering system programming mode (p. 23).

Remote
operation

The handset is operating the answering system remotely (p. 76).

Save error

During a programming procedure, the handset has lost communication with the base unit. Move closer to the base unit.

Base unit only

SUN 12:00AM
5 new calls
10 messages

In the standby mode, the display shows the current day and time, the number of new calls and recorded messages. (Ex. 5 new calls have been received and 10 messages have been recorded.)

SUN 12:00AM
0 message

When the clock needs adjusting, the day and time flash (p. 24).

5 new calls
<<=Old >>=New

This display will be shown when **CALLER ID** is pressed. To search from the most recent call, press **SKIP/FF** (New key). To search from the oldest call, press **REPEAT/REW** (Old key) (p. 36).

Greeting record
Recording error

Your greeting message was not recorded correctly. Record it again (p. 21).

► Displays

Greeting check

00-12

A greeting message is being played (p. 21). The display shows the elapsed time.

NANCY BROWN

↓-000-222-3333 ↯

↯- Answering - ↯

The answering system is recording a message (p. 59). (“- Answering -” flashes.)

SUN 12:00AM

↯ 5 new calls ↯

↯ Message full ↯

Message memory is full. (“Message full” flashes.) Erase some or all of the messages (p. 63).

PAGER

SUN 12:00AM

5 new calls

10 messages

The pager call mode is set to ON (p. 69).

SUN 12:00AM

Ringer off

10 messages

The ringer volume is set to OFF (p. 20).

Handset in use

This display will be shown when the handset is used (making/answering a call, viewing the Caller List or directory list, etc.).

Settings



Connections

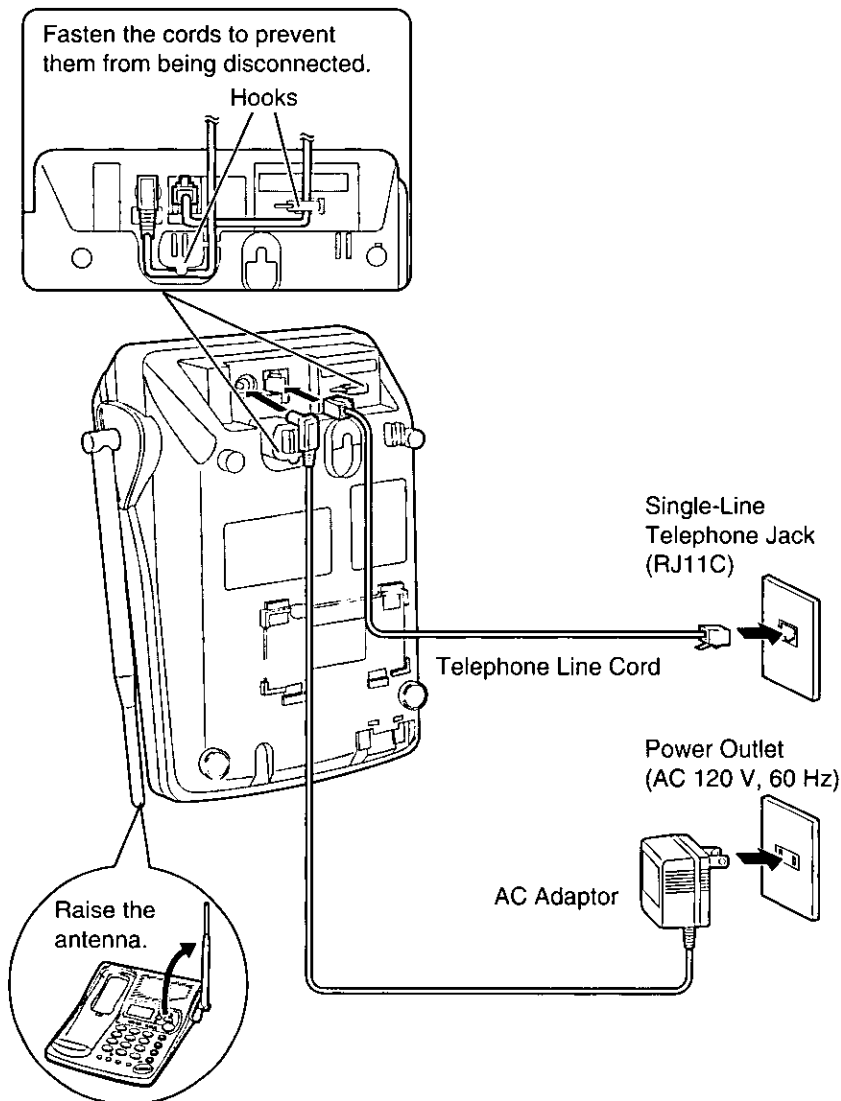

- USE ONLY WITH Panasonic AC ADAPTOR PQLV1 (Order No. PQLV1Z).
- The AC adaptor must remain connected at all times. (It is normal for the adaptor to feel warm during use.)
- To connect a standard telephone on the same line, see page 82.
- If your unit is connected to a PBX which does not support Caller ID services, you cannot access those services.

► Settings

Installing the Battery in the Handset

Install the battery and close the handset cover, locking it into place.

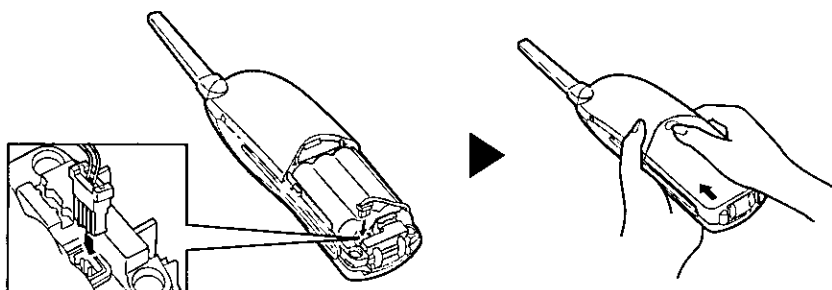

Battery Charge

Place the handset on the base unit and charge for about **6 hours** before initial use.

- The IN USE/CHARGE indicator lights.

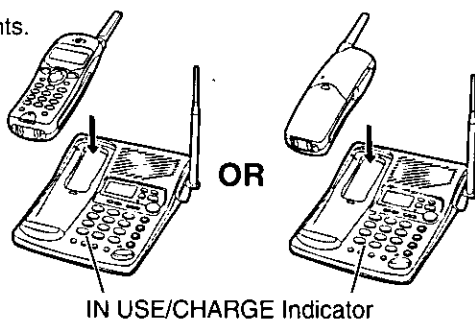

Battery strength

You can check the battery strength on the display while the handset is on the base unit, while it is in use (making/answering a call etc.), or after viewing the Caller List or directory items, programming etc.

The battery strength will remain for 5 seconds after using the handset, then the display will return to the standby mode (see next page).

The battery strength is as shown in the chart below.

Display prompt	Battery strength
{ ■■■ }	Fully charged
{ ■■ }	Medium
{ ■ }	Low
⚡ { ■ } ⚡ (flashing)	Needs to be recharged.



Recharge

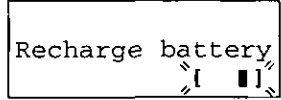

Recharge the battery when:

- “Recharge battery” is displayed,
- “[■]” flashes on the display, or
- the handset beeps intermittently while it is in use.

- If you DO NOT recharge the handset battery for more than 15 minutes, the display will keep indicating “Recharge battery” and/or “[■]” will continue to flash.

Battery information

After your Panasonic battery is fully charged (p. 14):

Operation		Approx. battery life
While in use (TALK)	near the base unit*	Up to about 6 hours
	away from the base unit	Up to about 4 hours
While not in use (Standby)		Up to about 14 days

*Within about 10 feet (3 m)

- Battery life may be shortened depending on usage conditions, such as viewing the Caller ID Caller List or directory list, and ambient temperature.
- Clean the handset and the base unit charge contacts with a soft, dry cloth once a month. Clean more often if the unit is subject to grease, dust or high humidity.** Otherwise the battery may not charge properly.
- If the battery is fully charged, you do not have to place the handset on the base unit until “Recharge battery” is displayed and/or “[■]” flashes. This will maximize the battery life.
- The battery cannot be overcharged.

Standby Mode

Handset (While off the base unit)

The handset goes into the standby mode after you finish using the handset (making/answering a call, viewing the Caller List or directory list etc.). The display is blank, but the handset can receive calls. The battery life is conserved in this mode.

Base Unit

The base unit goes into the standby mode after you finish using the base unit (making/answering a call, using the intercom, using the answering system etc.). Programming and storing phone numbers are possible only when the base unit is in the standby mode.

► Settings

Selecting the Dialing Mode

You can program the dialing mode **using the handset near the base unit**.

If you have touch tone service, set to "Tone". If rotary or pulse service is used, set to "Pulse". Your phone comes from the factory set to "Tone".

Make sure the unit is in the standby mode.

1 Press **FUNCTION/EXIT/CH**.

```
►Save directory
  Calling pager
▼▲                ►=Yes
```

2 Press **▼** or **▲** repeatedly until the arrow points to "Program".

```
  Ringer volume
►Program
▼▲                ►=Yes
```

3 Press **FWD/EDIT** **▶** (Yes key).

```
►Save DIRECT#
  Set flash time
▼▲                ►=Yes
```

4 Press **▼** or **▲** repeatedly until the arrow points to "Set dial mode".

```
  Set line mode
►Set dial mode
▼▲                ►=Yes
```

5 Press **FWD/EDIT** **▶** (Yes key).

```
Dial mode
                :Tone
▼▲                ►=Save
```

6 Press **▼** or **▲** to select "Pulse" or "Tone". Press **FWD/EDIT** **▶** (Save key).

```
Dial mode
                :Pulse
```

- A beep sounds.
- To return to the standby mode, press **FUNCTION/EXIT/CH**.

• You can exit the programming mode any time by pressing **FUNCTION/EXIT/CH**.

Selecting the Line Mode

If the line is connected to a low voltage system such as a PBX, set to "B". Otherwise the Call Waiting Caller ID Feature may not be accessible (p. 57), and the unit may not alert your pager (p. 64). Your phone comes from the factory set to "A".

Make sure the unit is in the standby mode.

- 1 Press **FUNCTION/EXIT/CH**.

▶Save directory
 Calling pager
 ▼▲ ▶=Yes
- 2 Press ▼ or ▲ repeatedly until the arrow points to "Program".

Ringer volume
 ▶Program
 ▼▲ ▶=Yes
- 3 Press **FWD/EDIT** ▶ (Yes key).

▶Save DIRECT#
 Set flash time
 ▼▲ ▶=Yes
- 4 Press ▼ or ▲ repeatedly until the arrow points to "Set line mode".

▶Set line mode
 Set dial mode
 ▼▲ ▶=Yes
- 5 Press **FWD/EDIT** ▶ (Yes key).

Line mode :A
 ▼▲ ▶=Save
- 6 Press ▼ or ▲ to select "B" or "A".
 Press **FWD/EDIT** ▶ (Save key).

Line mode :B

 - A beep sounds.
 - To return to the standby mode, press **FUNCTION/EXIT/CH**.

•You can exit the programming mode any time by pressing **FUNCTION/EXIT/CH**.

Programmable Functions

You can program the following function items **using the handset near the base unit**. The display shows the programming instructions. See the corresponding pages for function details.

Make sure the unit is in the standby mode.

Press **FUNCTION/EXIT/CH**.



<Function menu>*



▶ Save directory	To store an item in the directory (p. 46).
Calling pager	To dial the stored pager number (p. 67).
Ringer volume	To select the ringer volume (p. 20).
Program	

Press **FWD/EDIT** .

<Function menu>*

▶ Save DIRECT#	To store a phone number in the DIRECT button (p. 43).
Set flash time	To select the flash time (p. 58).
Set line mode	To select the line mode (p. 17).
Set dial mode	To select the dial mode (p. 16).
Talk switching	To set the auto talk feature (p. 19).
TAD program	To program answering system functions (p. 23).

During programming

*To select a desired function item, press  or  repeatedly until the arrow points to the item. Then press **FWD/EDIT**  to go to the next step.

- If the handset displays "No link to base. Place on cradle and try again." and an alarm tone sounds, move closer to the base unit and try again.
- You can exit the programming mode any time by pressing **FUNCTION/EXIT/CH**.
- If you do not press any buttons for 60 seconds, the unit will return to the standby mode.



Setting the Auto Talk Feature

The Auto Talk feature allows you to answer a call by lifting the handset off the base unit without pressing **TALK**. If you want to use this feature, turn the feature ON by programming. Your phone comes from the factory set to OFF.

Make sure the unit is in the standby mode.

1 Press **FUNCTION/EXIT/CH**.

2 Press or repeatedly until the arrow points to "Program".

```
Ringer volume
▶Program
▼▲ ▶=Yes
```

3 Press **FWD/EDIT** (Yes key).

4 Press or repeatedly until the arrow points to "Talk switching".

```
▶Talk switching
TAD program
▼▲ ▶=Yes
```

5 Press **FWD/EDIT** (Yes key).

```
Auto talk
:Off
▼▲ ▶=Save
```

6 Press or to select "On" or "Off".
Press **FWD/EDIT** (Save key).

```
Auto talk
:On
```

- A beep sounds.
- To return to the standby mode, press **FUNCTION/EXIT/CH**.

- You can exit the programming mode any time by pressing **FUNCTION/EXIT/CH**.
- To answer a call when the Auto Talk feature is OFF, lift the handset off the base unit and press **TALK**.

► Programmable Functions

Selecting the Ringer Volume

With the handset

You can program the ringer volume to HIGH, LOW or OFF. If set to OFF, the unit will not ring. Your phone comes from the factory set to HIGH.

Make sure the unit is in the standby mode.

- 1 Press **FUNCTION/EXIT/CH**.
- 2 Press **▼** or **▲** repeatedly until the arrow points to "Ringer volume", and press **FWD/EDIT** (▶) (Yes key).

- 3 Press **▼** or **▲** to select the desired volume.
 - The selected volume is displayed and rings.
 - To turn the ringer OFF, press and hold **▼** until 2 beeps sound.
 - The handset will return to the standby mode.

To turn the ringer ON, press **▲** or **▼** in step 3.

- The ringer will sound at the LOW level.

- When you replace the battery, the selected ringer volume setting will return to the factory set (HIGH). Reprogram if necessary.

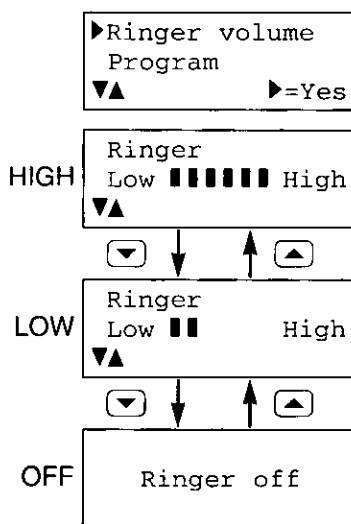

With the base unit

Make sure the unit is in the standby mode.

- To select HIGH (preset) or LOW**, press **RINGER**.

Each time you press the button, the ringer volume will change and the selected volume will ring.

- To turn the ringer OFF**, press and hold **RINGER** until 2 beeps sound. "Ringer off" will be displayed.
- To turn the ringer ON**, press **RINGER**. The ringer will sound at the HIGH level.

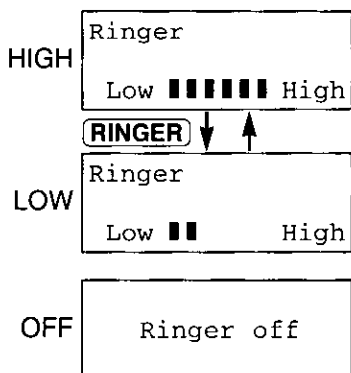

Preparing the Answering System

Greeting Message

You can record a personal greeting message of **up to 2 minutes**. If a greeting message is not recorded, one of two pre-recorded greetings will be played when a call is received (p. 22).

All messages (greeting, incoming, etc.) are stored in digital memory (p. 22). The **total recording time is about 15 minutes**.

We recommend you record a **brief greeting message** (see sample on next page) in order to leave more time for recording new messages.

Preparation

To record a greeting message

- 1** Press and hold **GREETING/EDIT** until a long beep is heard.

Greeting record
00-00

- 2** Talk clearly, about 8 inches (20 cm) away from the **MIC** (microphone).

- The base unit display shows the elapsed recording time.
- If you record for over 2 minutes, the unit will automatically stop recording.

Greeting record
00-12



- 3** When finished, press **STOP/EXIT**.

- To check the recorded greeting, press **GREETING/EDIT** briefly.

Greeting check
00-12

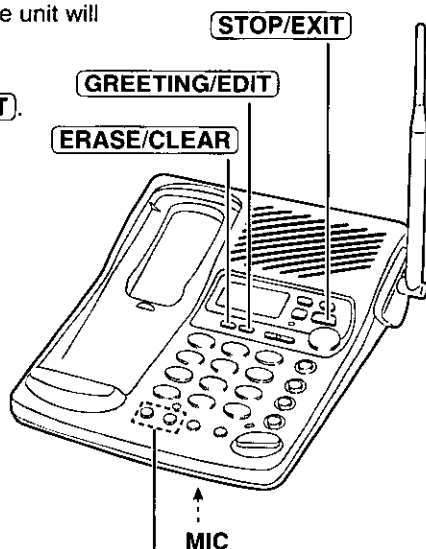
- To change the message, start again from step 1.



To increase the volume, press VOLUME  .
To decrease, press VOLUME  .

► Preparing the Answering System

Greeting message sample

"Hello, this is (your name and/or number). Sorry I cannot take your call. Please leave a message after the beep. Thank you."

To erase the recorded greeting message

Press **[GREETING/EDIT]** briefly → Press **[ERASE/CLEAR]** while the message is being played.

- The unit will answer a call with a pre-recorded greeting.

Pre-recorded greeting message

If you do not record a greeting message (p. 21), one of two messages will be played when a call is received, depending on the caller's recording time (p. 26).

To check the pre-recorded greeting, press **[GREETING/EDIT]** briefly.

- A pre-recorded greeting will be played as follows:

■ When the recording time is set to "1 minute" or "3 minutes":

"Hello, we are not available now. Please leave your name and phone number after the beep. We will return your call."

■ When the recording time is set to "Greeting only":

"Hello, we are not available now. Please call again. Thank you for your call."

Flash Memory Message Backup

Messages are stored on a "flash memory" IC chip and will not be affected by power failures. All messages are saved until you erase them.



Programming Summary for the Answering System

You can program the following functions **using the handset near the base unit**. See the page numbers below for details.

The unit must be in the standby mode before programming.

Lift the handset, and press **FUNCTION/EXIT/CH**.



Press **▼** or **▲** to select "Program", and press **FWD/EDIT ▶** (Yes key).



Press **▼** or **▲** to select "TAD program", and press **FWD/EDIT ▶** (Yes key).

• "Answering system setting. See base unit." is displayed on the handset.



• If the handset displays "No link to base. Place on cradle and try again." and an alarm tone sounds, move closer to the base unit and try again.

To adjust the **day and time**, press **0**. (page 24)

To set the **remote code**, press **1**. (page 71)

To select the **number of rings**, press **2**. (page 27)

To select the **caller's recording time**, press **5**. (page 26)

To select the **pager mode setting**, press **6**. (page 68)

To store **your home telephone number**, press **7**. (page 66)

To store a **pager number**, press **#**. (page 64)

• The base unit display shows the setting of the selected adjustment or function.



Press **FWD/EDIT ▶** (Save key).

• A beep sounds.

• To return to the standby mode, press **FUNCTION/EXIT/CH**.

• To cancel during programming, press **FUNCTION/EXIT/CH**. Start again from the beginning.

• If 6 beeps sound during programming, a wrong key was pressed. Enter the correct number.

► Preparing the Answering System

Day and Time Adjustment

Voice Day/Time Stamp: During playback, a synthesized voice will announce the day and time that each message was recorded.

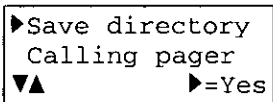
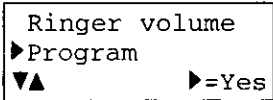
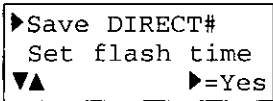
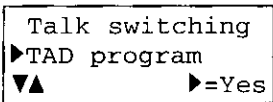
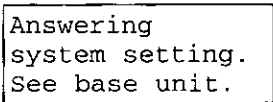
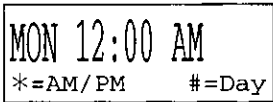
- 1 Press **FUNCTION/EXIT/CH**.

- 2 Press **▼** or **▲** repeatedly until the arrow points to "Program".

- 3 Press **FWD/EDIT** **▶** (Yes key).

- 4 Press **▼** or **▲** repeatedly until the arrow points to "TAD program".

- 5 Press **FWD/EDIT** **▶** (Yes key).
 - The base unit display shows the answering system function menu.
- 6 Press **0**.
 - "Set time" is announced.
If previously adjusted, the day/time will be heard.
- 7 Enter the current time (hour and minute) using a 4-digit number.
(Ex. To set 9:30, enter "0930".)
- 8 Press ***** to select "AM" or "PM".
Press **#** repeatedly to set the day.
- 9 Press **FWD/EDIT** **▶** (Save key).
 - The unit announces the day/time.
The clock starts working.
 - To return to the standby mode, press **FUNCTION/EXIT/CH**.



- In step 7, you cannot enter numbers greater than 12. **Do not use military time.** (To set 13:00 hours, enter "0100" and select "PM" by pressing **[*]**.)

If a power failure occurs, "⊖" will flash or the incorrect day/time will be shown on the main unit display. Reprogram the current day/time.

To check the day/time

Repeat steps 1 to 6 on page 24.

- The current day/time is heard. When finished, press **[FUNCTION/EXIT/CH]**.

For Caller ID service users (p. 34)

- The Caller ID information will re-set the clock after the first ring if the adjusted time is incorrect. However, the day will not be re-set by the Caller ID information. Adjust the correct day by following the steps on page 24.
- If the time has not previously been set, the Caller ID information will not adjust the clock.
- The Caller ID information will automatically adjust the clock for daylight saving time.

► Preparing the Answering System

Selecting the Caller's Recording Time

You can select "1 minute", "3 minutes" or "Greeting only" for the caller's recording time. Your phone comes from the factory set to "3 minutes".

1 Press **FUNCTION/EXIT/CH**.

► Save directory
Calling pager
▼▲ ▶=Yes

2 Press ▼ or ▲ repeatedly until the arrow points to "Program".

Ringer volume
► Program
▼▲ ▶=Yes

3 Press **FWD/EDIT** ► (Yes key).

► Save DIRECT#
Set flash time
▼▲ ▶=Yes

4 Press ▼ or ▲ repeatedly until the arrow points to "TAD program".

Talk switching
► TAD program
▼▲ ▶=Yes

5 Press **FWD/EDIT** ► (Yes key).
• The base unit display shows the answering system function menu.

Answering
system setting.
See base unit.

6 Press **5**.
• The current setting is displayed on the base unit.

Base unit display
Recording time
:3min

7 Press **1**, **2** or **3** to select the recording time.
1: 1 minute
2: 3 minutes (factory preset)
3: Greeting only

8 Press **FWD/EDIT** ► (Save key).
• A beep sounds.
• To return to the standby mode, press **FUNCTION/EXIT/CH**.

If you select "Greeting only", the unit will answer a call with the greeting message, and then hang up. The unit will not record any incoming messages.

Selecting the Number of Rings

You can select the number of times the unit rings before the answering system answers a call, from "2" to "7" or "Toll saver".

Your phone comes from the factory set to "Toll saver".

1 Press **FUNCTION/EXIT/CH**.

▶ Save directory
Calling pager
▼▲ ▶=Yes

2 Press **▼** or **▲** repeatedly until the arrow points to "Program".

Ringer volume
▶ Program
▼▲ ▶=Yes

3 Press **FWD/EDIT** **▶** (Yes key).

▶ Save DIRECT#
Set flash time
▼▲ ▶=Yes

4 Press **▼** or **▲** repeatedly until the arrow points to "TAD program".

Talk switching
▶ TAD program
▼▲ ▶=Yes

5 Press **FWD/EDIT** **▶** (Yes key).

- The base unit display shows the answering system function menu.

Answering system setting.
See base unit.

6 Press **2**.

- The current setting is displayed on the base unit.

Base unit display

Number of rings
:Toll saver

7 Press **0**, or **2** to **7** to set the number of rings.

0: Selects "Toll saver".

2-7: The unit will answer after the selected number of rings.

8 Press **FWD/EDIT** **▶** (Save key).

- A beep sounds.

- To return to the standby mode, press **FUNCTION/EXIT/CH**.

*Toll saver

When you call the unit from a touch tone telephone:

If the unit answers on the 2nd ring, there is at least one new message.

If the unit answers on the 4th ring, there are no new messages.

Hang up when you hear the 3rd ring. This will save you the toll charge for the call.

Making Calls

With the Handset

To have a hand-free conversation, connect the headset to the handset (p. 80).

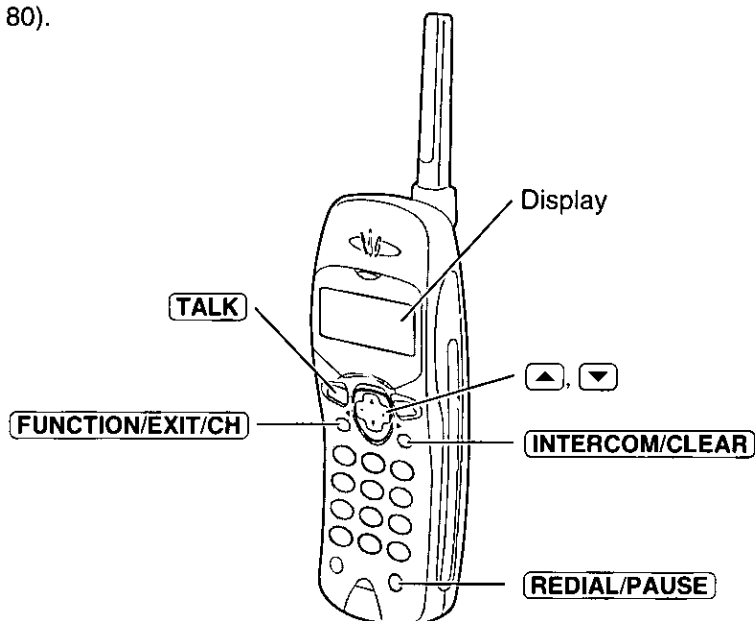

1 Press **TALK**.



2 Dial a phone number.

- The dialed number is displayed.
- After a few seconds, the display will show the length of the call and the battery strength.

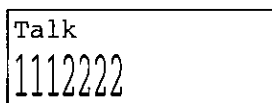

3 To hang up, press **TALK** or place the handset on the base unit.

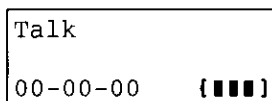

If noise interferes with the conversation

Press **FUNCTION/EXIT/CH** to select a clearer channel or move closer to the base unit.

To redial the last number dialed on the handset

Press **TALK** → **REDIAL/PAUSE**.



To dial after confirming the entered number

- 1 Dial a phone number.
- If you misdial, press **INTERCOM/CLEAR**. All digits are erased. Dial the correct phone number.

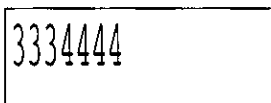

- 2 Press **TALK**.
- After a few seconds, the display will show the length of the call and the battery strength.

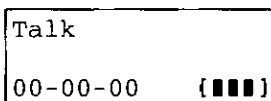
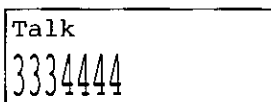

- 3 To hang up, press **TALK** or place the handset on the base unit.

To redial after confirming the last number dialed

Press **REDIAL/PAUSE** → **TALK**.

To select the receiver volume

Press **▲** or **▼** while talking.

- Each time you press **▲** or **▼**, the volume level will change.
- The display will return to the length of the call.
- Your phone comes from the factory set to MEDIUM.
- When you replace the battery, the selected receiver volume setting will return to the factory set (MEDIUM). Reprogram if necessary.

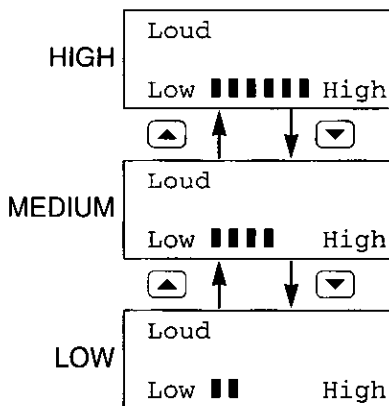

Backlit LCD display

The lighted handset display will stay on for about 10 seconds after pressing a handset button or lifting the handset off the base unit.

Lighted handset keypad

The handset dialing buttons will light when you press a button or lift the handset off the base unit, and flash when a call is received. The lights will go out about 10 seconds after pressing a button, lifting the handset or answering a call.

► Making calls

With the Base Unit

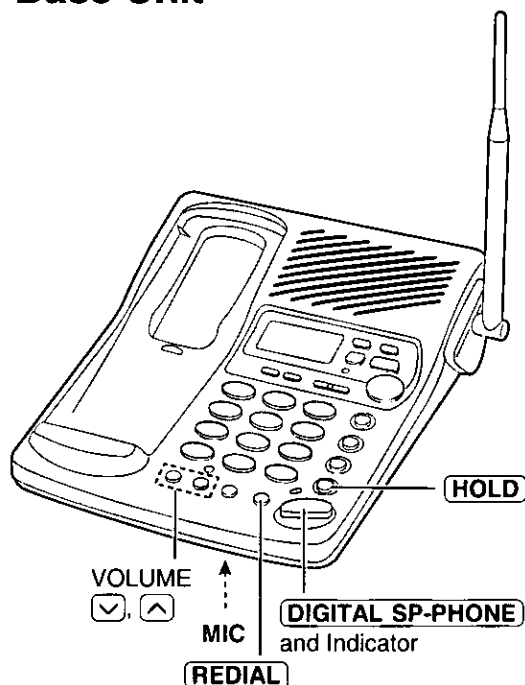

- 1** Press **DIGITAL SP-PHONE**.
•The DIGITAL SP-PHONE indicator lights.

Talk

- 2** Dial a telephone number.

Talk
1112222

- 3** When the other party answers, talk into the **MIC** (microphone).

Talk
00-00-00



- 4** To hang up, press **DIGITAL SP-PHONE**.
•The indicator light goes out.

- To switch to the handset while using the speakerphone:
 - If the handset is off the base unit, press **TALK**.
 - If on the base unit, just lift up.
- During a call using the handset, the call can be switched to the speakerphone by pressing **DIGITAL SP-PHONE** on the base unit.



Hands-free Digital Speakerphone

For best performance, please note the following:

- Talk alternately with the caller in a quiet room.
- If the other party has difficulty hearing you, press **VOLUME**  to decrease the speaker volume.
- If the other party's voice from the speaker cuts in/out during a conversation, press **VOLUME**  to decrease the speaker volume.

To adjust the speaker volume (8 levels) while talking

To increase, press **VOLUME** .

To decrease, press **VOLUME** .



To redial the last number dialed on the base unit

Press **DIGITAL SP-PHONE** → **REDIAL**.

To put a call on hold

Press **HOLD**.

- The DIGITAL SP-PHONE indicator flashes.



To release the hold

From the base unit, press **DIGITAL SP-PHONE**.

From the handset, press **TALK** or lift the handset off the base unit.

- If another phone is connected on the same line (p. 82), you can also release the hold by lifting its handset.

► Making calls

Simultaneous Keypad Dialing

You can use the base unit like a standard telephone. After pressing **TALK** to make a call with the handset near the base unit, you can also dial using the base unit keypad.

- 1 Handset:
Press **TALK**.
- 2 Base unit:
Dial a telephone number while hearing a dial tone on the handset.
 - When the other party answers, talk using the handset.
- 3 Handset:
To hang up, press **TALK** or place the handset on the base unit.



Simultaneous Keypad Dialing is only possible after pressing **TALK**.

Useful information

You can enter numbers using the base unit keypad during a call with the handset. For example, to access an answering service, electronic banking service, etc.

1. Handset:
Press **TALK**.
2. Handset:
Dial a telephone number.
 - You can also dial with base unit keypad.
3. Base unit:
Enter the required numbers while listening to the pre-recorded instructions.
4. Handset:
To hang up, press **TALK** or place the handset on the base unit.

Answering Calls

When a call is received, the unit rings and the CALLER ID button on the base unit flashes quickly. If you subscribe to a Caller ID service, the calling party information will be displayed after the first ring (p. 34). In order to view the Caller ID information, please wait until the second ring to answer a call.

With the Handset

Lift the handset off the base unit and press

TALK.

- You can also answer a call by pressing any dialing button **0** to **9**, ***** or **#** (—Any Key Talk).



Auto Talk

If you set the Auto Talk feature to ON (p. 19), you can answer a call by lifting the handset off the base unit without pressing **TALK**.

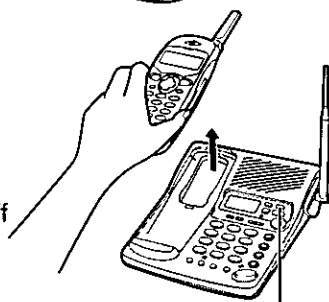

CALLER ID button

When the headset is connected (p. 80), make sure to use the headset to talk with the caller. If you want to have a normal cordless phone conversation, disconnect the headset.

With the Base Unit

- 1 Press **DIGITAL SP-PHONE**.
 - The DIGITAL SP-PHONE indicator lights.
- 2 Talk into the **MIC**.
- 3 To hang up, press **DIGITAL SP-PHONE**.
 - The indicator light goes out.

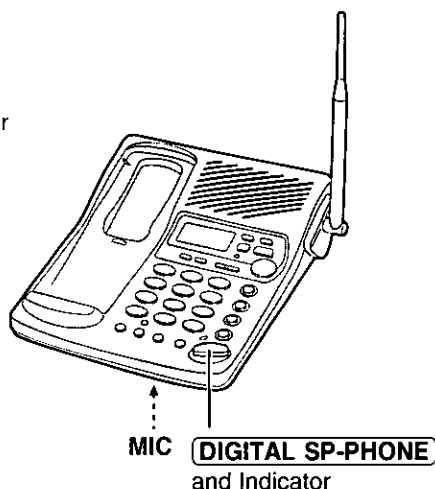

Cordless Telephone

Caller ID Service

This unit is compatible with a Caller ID service offered by your telephone company. If you subscribe to a Caller ID service, the calling party's information will be displayed on the handset and the base unit after the first ring.

The unit can record information of up to 50 different callers, including the time and date received and the number of times called, in the Caller List. The Caller List information is sorted by the most recent to the oldest call. When the 51st call is received, the first call is deleted.

Using the list, you can automatically call back a caller. You can store the callers' numbers from the Caller List into the directory.

If you subscribe to a Call Waiting Caller ID Feature, when a second call is received while talking, the new caller's name and phone number will be displayed (p. 57).

How caller information is displayed when a call is received

The handset and the base unit displays show the caller's name and number after the first ring.

- If the handset is on the base unit, the caller's information will be displayed on the base unit only
- After you answer the call, the display will show the length of the call.

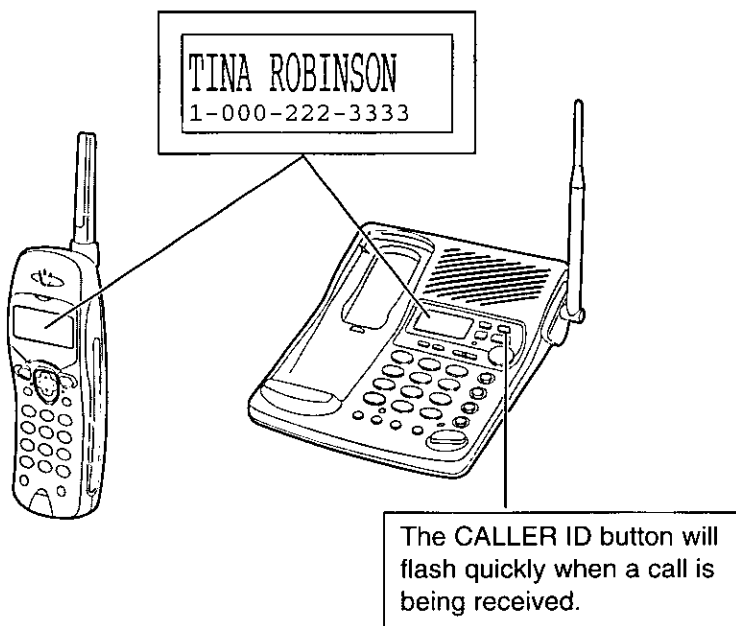

- Caller information cannot be displayed in the following cases:
 - If the caller dialed from an area which does not provide a Caller ID service, the display will show "Out of area".
 - If the caller has requested not to display his/her information, the display will show "Private caller".
- If your unit is connected to a PBX which does not support Caller ID services, you cannot access those services.
- The name display service may not be available in some areas. For further information, please contact your telephone company.

To check the number of new calls

When new calls have been received, the CALLER ID button flashes slowly on the base unit.

Ex. You have received 10 new calls.

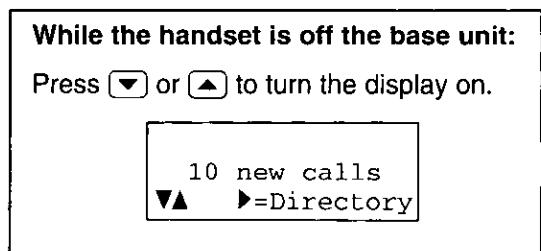
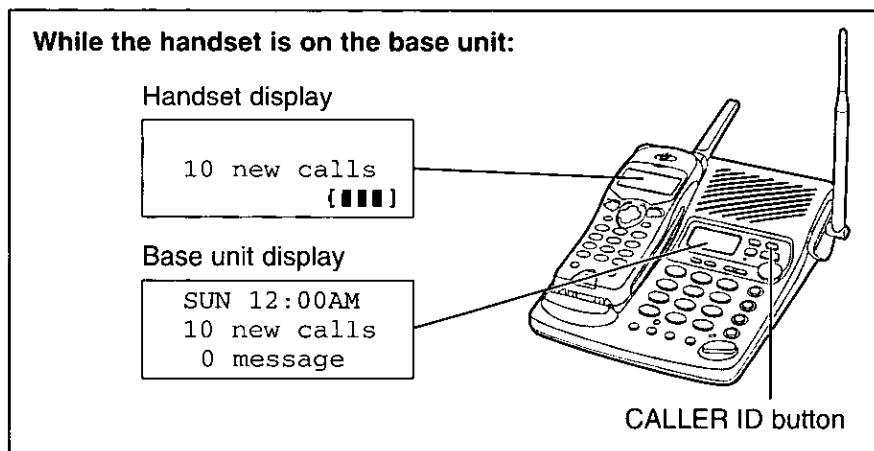



Using the Caller List

Viewing the Caller List

To check who has called, follow the steps below.

Make sure the unit is in the standby mode.



With the handset



1 Lift the handset off the base unit and press  or  to enter the Caller List.

- The display will show, for example, the following:

```
2 new calls
▼▲ ▶=Directory
```

- You can go to the directory list by pressing **FWD/EDIT**  (p. 45).

2 To search from the most recent call, press . To search from the oldest call, press .

- To scroll between callers, press  or .

```
JACK SMITH
1-222-333-4444
3:10P JUN.10
```

3 To exit the list, press **FUNCTION/EXIT/CH**.

- The handset will return to the standby mode.

With the base unit

1 Press **CALLER ID** to enter the Caller List.

- The display will show, for example, the following:

```
2 new calls
<<=Old >>=New
```

2 To search from the most recent call, press **SKIP/FF**. To search from the oldest call, press **REPEAT/REW**.

- To scroll between callers, press **SKIP/FF** or **REPEAT/REW**.

```
JACK SMITH
1-222-333-4444
3:10P JUN.10
```

3 To exit the list, press **STOP/EXIT**.

- The base unit will return to the standby mode.

- Once new calls have been checked, “√” will be added.
- If “No items stored” is displayed in step 1, the Caller List is empty. After 5 seconds, the unit will return to the standby mode.
- If more than one call is received from the same caller, the date and time of the most recent call will be recorded. If the same caller calls again, the call entry with “√” will be deleted.



Display meaning

√ : You have checked this caller information, answered the call or called back the caller.

JACK SMITH
1-222-333-4444
3:10P JUN.10 √

×2-×9 : The number of times the same caller called (up to 9). After checking, "×2"- "×9" will be replaced with "√".

JACK SMITH
1-222-333-4444
3:10P JUN.10 ×3

Calling Back from the Caller List

With the handset

- 1 Lift the handset off the base unit and press or to enter the Caller List.

3 new calls
▼▲ ▶=Directory

- 2 Press or repeatedly to find the desired caller.

CINDY TURNER
1-234-456-7890
11:20A JAN.12 ×3

- 3 Press **TALK**.
•The displayed phone number is dialed automatically.

Talk
12344567890

With the base unit

- 1 Press **CALLER ID** to enter the Caller List.

3 new calls
<<=Old >>=New

- 2 Press **SKIP/FF** or **REPEAT/REW** repeatedly to find the desired caller.

CINDY TURNER
1-234-456-7890
11:20A JAN.12 ×3

- 3 Press **DIGITAL SP-PHONE**.
•The displayed phone number is dialed automatically.

Talk
12344567890

- In some cases, you may have to edit the number before dialing (p. 38, 39).
(Ex. You may have to delete "1" and the area code.)
- If a phone number is not displayed in the caller information, you cannot call back that caller.



► Using the Caller List

Editing the Caller's Phone Number

The unit can edit a phone number into one of 4 patterns.

Make sure the unit is in the standby mode.

With the handset

1 Lift the handset off the base unit and press  or  to enter the Caller List.

2 Press  or  repeatedly to find the desired caller. Press **FWD/EDIT** .

3 While the arrow points to "Edit", press **FWD/EDIT**  (Yes key).

4 Press **FWD/EDIT**  (Edit key) to select a pattern.

- Each time you press **FWD/EDIT** , the number is rearranged into one of 4 different patterns.

- (a)
- (b) -
- (c) 1 -
- (d) 1 - -

- The order in which patterns (a)–(d) are displayed depends on how the telephone number is displayed in step 2.
- You should complete editing a number within 60 seconds.

5 After editing the number, you can continue with calling back or storing procedures.

To call back, press **(TALK)** (p. 37).

To store the number in the directory, press  (Next key). Follow the instructions on the display (p. 40).

```
5 new calls
▼▲ ▶=Directory
```

```
FRED PARKER
1-234-321-5555
11:20A JAN.12 ✓
```

```
▶Edit
Save directory
▼▲ ▶=Yes
```

```
FRED PARKER
1-234-321-5555
▼=Next ▶=Edit
```

```
(a) FRED PARKER
321-5555
▼=Next ▶=Edit
```

```
(b) FRED PARKER
234-321-5555
▼=Next ▶=Edit
```

```
(c) FRED PARKER
1-321-5555
▼=Next ▶=Edit
```

```
(d) FRED PARKER
1-234-321-5555
▼=Next ▶=Edit
```

```
FRED PARKER
321-5555
▲=Edit ▶=Save
```

- The number edited in step 4 will not be maintained in the Caller List.



With the base unit

- 1 Press **CALLER ID** to enter the Caller List.

```

5 new calls
<<=Old   >>=New
  
```

- 2 Press **SKIP/FF** or **REPEAT/REW** repeatedly to find the desired caller.

```

FRED PARKER
1-234-321-5555
11:20A JAN.12 ✓
  
```

- 3 Press **GREETING/EDIT** to select a pattern.

- Each time you press **GREETING/EDIT**, the number is rearranged into one of 4 different patterns.

- (a)
 (b) -
 (c) 1 -
 (d) 1 - -

- The order in which patterns (a)-(d) are displayed depends on how the telephone number is displayed in step 2.

(a)

```

FRED PARKER
321-5555
11:20A JAN.12 ✓
  
```

(b)

```

FRED PARKER
234-321-5555
11:20A JAN.12 ✓
  
```

(c)

```

FRED PARKER
1-321-5555
11:20A JAN.12 ✓
  
```

(d)

```

FRED PARKER
1-234-321-5555
11:20A JAN.12 ✓
  
```

Cordless Telephone

- 4 After editing the number, you can continue with calling back. To call back, press **DIGITAL SP-PHONE** (p. 37).

- The number edited in step 3 will not be maintained in the Caller List.



► Using the Caller List

Storing Caller List Information in the Directory

You can store numbers that are in the Caller List in the directory.

This feature can operate only with the handset.

Make sure the unit is in the standby mode.

1 Lift the handset off the base unit and press  or  to enter the Caller List.



```
10 new calls
▼▲ ▶=Directory
```

2 Press  or  repeatedly to find the caller you want to store in the directory. Press **FWD/EDIT**  (Yes key).

```
CINDY TURNER
1-234-456-7890
11:20A JAN.12 x3
```

•If the number requires editing, see page 38.



```
▶Edit
Save directory
▼▲ ▶=Yes
```



3 Press  or  to select "Save directory". Press **FWD/EDIT**  (Yes key).

```
Edit
▶Save directory
▼▲ ▶=Yes
```

If there is no name information for the caller, "Enter name" will be displayed.

```
Enter name
◀▶ ▼=Next
```

a) If a name is not required, press  (Next key) and **FWD/EDIT**  (Save key).

b) If a name is required, enter the name (p. 47). When finished, press  (Next key) and **FWD/EDIT**  (Save key).

```
Enter name
CINDY TURNER
◀▶ ▼=Next
```

•A beep sounds.

•The display will return to step 2. You can continue storing other items.

```
CINDY TURNER
12344567890
▶=Save
```

To return to the standby mode, press **FUNCTION/EXIT/CH**.

•You can exit the programming mode any time by pressing **FUNCTION/EXIT/CH**.

•If the display shows "Directory full" in step 3, the display will return to step 2. Press **FUNCTION/EXIT/CH** to exit the list. To erase other stored items from the directory, see page 53.

•You cannot store caller information in the directory if a phone number is not displayed.

•If the display shows "Save error" or "No link to base. Place on cradle and try again." in step 3, the item cannot be stored in the directory. Try again from step 1.



Erasing Caller List Information

After checking the Caller List, you can erase some or all of the entries. **Make sure the unit is in the standby mode.**

To erase a specific caller from the Caller List

With the handset

- 1 Lift the handset off the base unit and press or to enter the Caller List.

10 new calls
▼▲ ▶=Directory

- 2 Press or repeatedly to find the caller you want to erase from the Caller List.

TOM REAGAN
1-888-777-6666
12:20A JAN.12 ✓

- 3 Press **INTERCOM/CLEAR**.

Clear

- A beep sounds and the information is erased.
- To erase other items, repeat from step 2.
- To return to the standby mode, press **FUNCTION/EXIT/CH**.

With the base unit

- 1 Press **CALLER ID** to enter the Caller List.

10 new calls
<<=Old >>=New

- 2 Press **SKIP/FF** or **REPEAT/REW** repeatedly to find the caller you want to erase from the Caller List.

TOM REAGAN
1-888-777-6666
12:20A JAN.12 ✓

- 3 Press **ERASE/CLEAR**.

Clear



- A beep sounds and the information is erased.
- To erase other items, repeat from step 2.
- To return to the standby mode, press **STOP/EXIT**.

► Using the Caller List

To erase all entries in the Caller List

Before erasing all entries, make sure that "0 new call" is displayed.



With the handset

- 1 Lift the handset off the base unit and press  or  to enter the Caller List.

```
0 new call
▼▲ ▶=Directory
```

- 2 Press **INTERCOM/CLEAR**.

```
▶Exit
All clear
▼▲ ▶=Yes
```

- 3 Press  or  to select "All clear".

```
Exit
▶All clear
▼▲ ▶=Yes
```

- 4 Press **FWD/EDIT**  (Yes key) or **INTERCOM/CLEAR**.

```
All clear
```

- A beep sounds and all entries are erased.
- The handset will return to the standby mode.

With the base unit

- 1 Press **CALLER ID** to enter the Caller List.

```
0 new call
<<=Old >>=New
```

- 2 Press **ERASE/CLEAR**.

```
Press CLEAR for
all clear
```

- 3 Press **ERASE/CLEAR** again.

```
All clear
```

- A beep sounds and all entries are erased.
- The base unit will return to the standby mode.

One-Touch Dialer



A phone number stored in the **DIRECT** button can be dialed with a one-touch operation.

Storing a Phone Number in the DIRECT Button

Make sure the unit is in the standby mode.

1 Press **FUNCTION/EXIT/CH**.

2 Press or repeatedly until the arrow points to "Program".

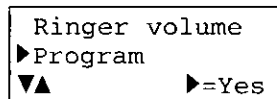

3 Press **FWD/EDIT** (Yes key).

4 While the arrow points to "Save DIRECT#", press **FWD/EDIT** (Yes key).

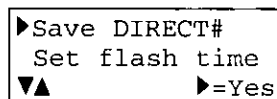

5 Enter a phone number, up to 48 digits.

- Each time you press **INTERCOM/CLEAR** the digit to the left of the cursor is erased. To erase all of the digits, press and hold **INTERCOM/CLEAR**.
- The last 32 digits number you entered will be displayed. To confirm the remaining number, press **BACK** or **FWD/EDIT** .

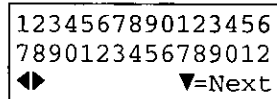
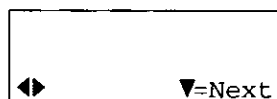

6 Press (Next key).

- If you want to edit the entered number, press (Edit key) and return to step 5.

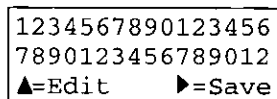

7 Press **FWD/EDIT** (Save key).

- A beep sounds.
- To return to the standby mode, press **FUNCTION/EXIT/CH**.

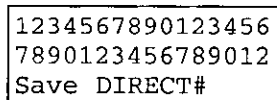

- You can exit the programming mode any time by pressing **FUNCTION/EXIT/CH**.
- If a pause is required for dialing, **REDIAL/PAUSE** can be stored in a phone number counting as one digit (p. 57) in step 5.

► One-Touch Dialer

Dialing the Stored Number in the DIRECT Button

- 1 Press **DIRECT**.
 - The stored number is dialed automatically.
 - After a few seconds, the display will show the length of the call and the battery strength.

Talk	Direct
D	

Talk
00-00-00 [■■■■]

- 2 To hang up, press **TALK** or place the handset on the base unit.

- You can also dial the stored number in the **DIRECT** button by pressing **TALK** and **DIRECT**.

Using the Directory



You can store up to 50 names and phone numbers in the directory. All directory items are sorted by the first word in alphabetical order. Using the directory, you can make a call by selecting a name on the handset or base unit display.

Storing Names and Numbers in the Directory

Make sure the unit is in the standby mode.

Cordless Telephone

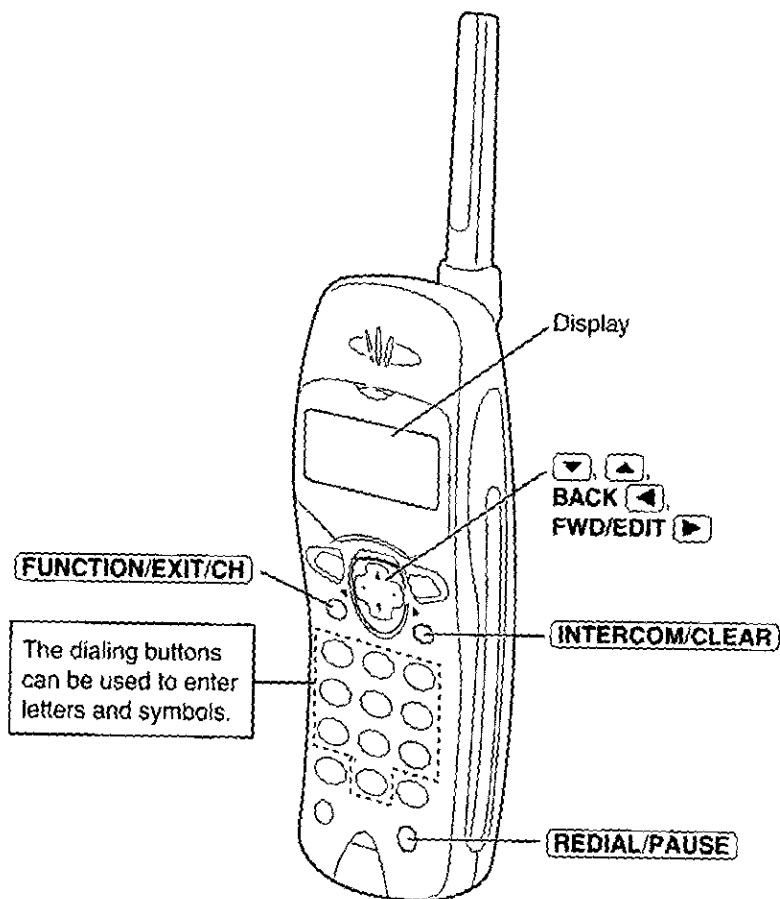

- While storing or finding items in the directory, "📖" will be shown on the display.

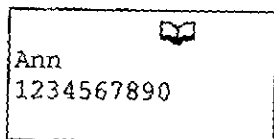

► Using the Directory

1 Press **FUNCTION/EXIT/CH**.

► Save directory
Calling pager
▼▲ ▶=Yes

2 While the arrow points to "Save directory", press **FWD/EDIT** (▶) (Yes key).

Directory=
20 items

- The display shows the number of stored items in the directory.

3 Enter a name, up to 15 characters, with the dialing buttons, **BACK** (◀) or **FWD/EDIT** (▶).

Enter name
◀▶ ▼=Next

- See the steps for entering names and symbols (p. 47).
- If a name is not required, press ▼ (Next key) and go to step 5.

Enter name
Tom Jones
◀▶ ▼=Next

4 Press ▼ (Next key).

Enter phone no.

5 Enter a phone number, up to 22 digits.

- Each time you press **INTERCOM/CLEAR**, a character is erased from the right. To erase all of the digits, press and hold **INTERCOM/CLEAR**.

0987654321
◀▶ ▼=Next

6 Press ▼ (Next key).

Tom Jones
0987654321
▶=Save

7 Press **FWD/EDIT** (▶) (Save key).

- A beep sounds.
- To continue storing other items, repeat from step 2.
- To return to the standby mode, press **FUNCTION/EXIT/CH**.

- If a pause is required for dialing, **REDIAL/PAUSE** can be stored in a phone number counting as one digit (p. 57) in step 5.
- You can exit the programming mode any time by pressing **FUNCTION/EXIT/CH**.
- If the display shows "Directory full" in step 2, the display will return to step 1. Press **FUNCTION/EXIT/CH** to exit the list. To erase other stored items from the directory, see page 53.
- If the display shows "save error" in step 7, the item cannot be stored in the directory. Try again from step 1.



Steps for Entering Names and Symbols

The handset dialing buttons (0 to 9), **BACK** ◀ and **FWD/EDIT** ▶ can be used to enter letters and symbols.

Each button selects a character as shown below.

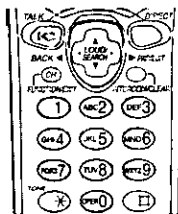

Keys	Number of times key is pressed										
	1	2	3	4	5	6	7	8	9	10	11
1	#	&	'	()	*	,	-	.	/	1
2	A	B	C	a	b	c	2				
3	D	E	F	d	e	f	3				
4	G	H	I	g	h	i	4				
5	J	K	L	j	k	l	5				
6	M	N	O	m	n	o	6				
7	P	Q	R	S	p	q	r	s	7		
8	T	U	V	t	u	v	8				
9	W	X	Y	Z	w	x	y	z	9		
0	0	Blank									
BACK ◀	To move the cursor to the left										
FWD/EDIT ▶	To move the cursor to the right										

Cordless Telephone

- To enter another character using the same dialing button, press **FWD/EDIT** ▶ to move the cursor to the next space.







If you make a mistake while entering a name

Use **BACK** ◀ or **FWD/EDIT** ▶ to move the cursor to the incorrect character, press **INTERCOM/CLEAR** to delete and enter the correct character. Each time you press **INTERCOM/CLEAR**, a character is erased from the right.

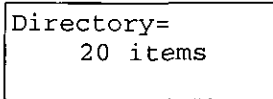
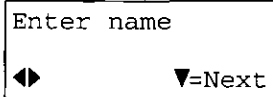
To erase all characters, press and hold **INTERCOM/CLEAR**.

► Using the Directory

For example, to enter "Tom Jones":

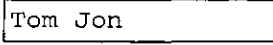
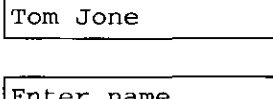
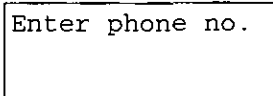
- 1 Press **FUNCTION/EXIT/CH**.
- 2 While the arrow points to "Save directory", press **FWD/EDIT** (▶) (Yes key).

- 3 Press **8**.

- 4 Press **6** six times, then press **FWD/EDIT** (▶) to move the cursor to the right.

- 5 Press **6** four times.

- 6 Press **FWD/EDIT** (▶) twice to enter a blank.

- 7 Press **5**.

- 8 Press **6** six times, then press **FWD/EDIT** (▶) to move the cursor to the right.

- 9 Press **6** five times.

- 10 Press **3** five times.

- 11 Press **7** eight times.

- 12 When finished, press **▼** (Next key).
 - Follow steps 5 to 7 on page 46 to complete the operation.

• While entering names, the cursor will flash on the display.



Finding Items in the Directory

With the handset

Make sure the unit is in the standby mode.

- 1 Press **BACK** (◀) or **FWD/EDIT** (▶) to enter the directory list.

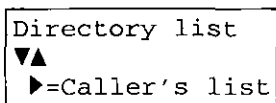

- 2 Press (▼) or (▲).
•The first item is displayed.

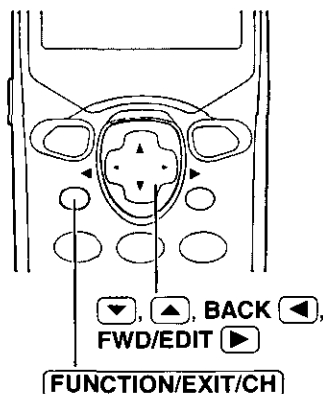
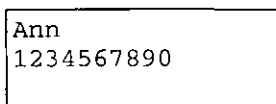

- 3 Press (▼) or (▲) repeatedly until the desired item is displayed.

- All directory items are stored in the order shown on the right.

To search for a name by the initial:

- ① Press the dialing button for the first letter of the desired name until any name with the same initial is displayed (see the Index table on page 51).
Ex. To find "Frank", press (3) repeatedly until the first item under "F" is displayed.
- ② Press (▼) until the name is displayed.

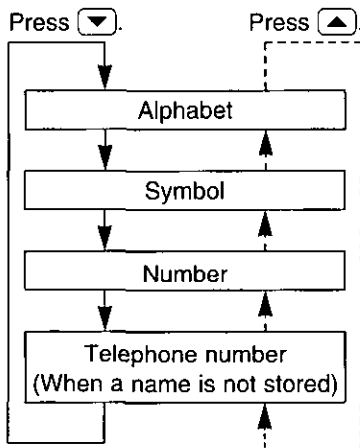

Cordless Telephone

- You can exit the directory list any time by pressing **FUNCTION/EXIT/CH**.
- If "No items stored" is displayed in step 2, the directory is empty. To return to the standby mode, press **FUNCTION/EXIT/CH**.
- In step 1, you can go to the Caller List by pressing **FWD/EDIT** (▶) (p. 36).

► Using the Directory

With the base unit

Make sure the unit is in the standby mode.

- 1 Press **DIRECTORY** to enter the directory list.

- The first item is displayed.

Ann
1234567890

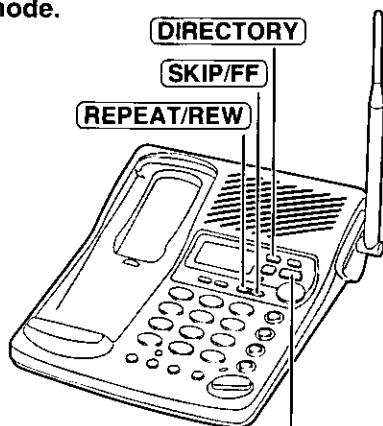

- 2 Press **SKIP/FF** or **REPEAT/REW** repeatedly until the desired item is displayed.

- All directory items are stored in the order shown on the right.

To search for a name by the initial:

- ① Press the dialing button for the first letter of the desired name until any name with the same initial is displayed (see the Index table on page 51).

Ex. To find "Frank", press **3** repeatedly until the first item under "F" is displayed.

- ② Press **SKIP/FF** until the name is displayed.

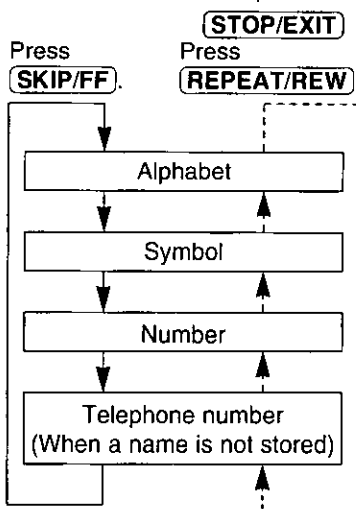

- You can exit the directory list any time by pressing **STOP/EXIT**.
- If "No items stored" is displayed in step 2, the directory is empty. To return to the standby mode, press **STOP/EXIT**.



Index table

Keys	Index	Keys	Index
①	Other symbols, 1	⑥	M, N, O, 6
②	A, B, C, 2	⑦	P, Q, R, S, 7
③	D, E, F, 3	⑧	T, U, V, 8
④	G, H, I, 4	⑨	W, X, Y, Z, 9
⑤	J, K, L, 5	⑩	0

Dialing from the Directory

With the handset

- 1 Press **BACK** (◀) or **FWD/EDIT** (▶) to enter the directory list.
- 2 Press (▼) or (▲).
•The first item is displayed.
- 3 Press (▼) or (▲) repeatedly to find the directory item that you want to dial (p. 49).

Frank
4567890

- 4 Press **TALK**.
•The number is dialed automatically.

Talk
4567890

- 5 To hang up, press **TALK** or place the handset on the base unit.

- You can exit the directory list any time by pressing **FUNCTION/EXIT/CH**.

With the base unit

- 1 Press **DIRECTORY** to enter the directory list.
•The first item is displayed.
- 2 Press **SKIP/FF** or **REPEAT/REW** repeatedly to find the directory item that you want to dial (p. 50).

Frank
4567890

- 3 Press **DIGITAL SP-PHONE**.
•The number is dialed automatically.

Talk
4567890

- 4 To hang up, press **DIGITAL SP-PHONE**.

- You can exit the directory list any time by pressing **STOP/EXIT**.

► Using the Directory

Editing an Item in the Directory

This feature can operate only with the handset.
Make sure the unit is in the standby mode.

1 Press **BACK** (◀) or **FWD/EDIT** (▶) to enter the directory list.

2 Press (▼) or (▲).
•The first item is displayed.

3 Press (▼) or (▲) repeatedly to find the directory item you want to change (p. 49). Press **FWD/EDIT** (▶).

```
Jane
1234567
```

```
Enter name
Jane
◀          ▼=Next
```

4 Edit the name using the dialing buttons, **BACK** (◀) or **FWD/EDIT** (▶) (p. 47), up to 15 characters.

```
Enter name
Jane Walker
◀          ▼=Next
```

5 Press (▼) (Next key).
•If you do not need to change the number, press (▼) (Next key) twice and go to step 8.

```
1234567
◀          ▼=Next
```

6 Add a number to the current number.
•Each time you press **INTERCOM/CLEAR** the digit to the left of the cursor is erased. To erase all of the digits, press and hold **INTERCOM/CLEAR**.

```
0981234567
◀          ▼=Next
```

7 Press (▼) (Next key).

```
Jane Walker
0981234567
          ▶=Save
```

8 When finished, press **FWD/EDIT** (▶) (Save key).

```
Jane Walker
0981234567
```

•To continue editing other items, repeat steps 3 through 8.

•To return to the standby mode, press **FUNCTION/EXIT/CH**.

•You can exit the directory list any time by pressing **FUNCTION/EXIT/CH**.

Erasing an Item from the Directory

Make sure the unit is in the standby mode.

With the handset

1 Press **BACK** (◀) or **FWD/EDIT** (▶) to enter the directory list.

2 Press (▼) or (▲).
•The first item is displayed.

3 Press (▼) or (▲) repeatedly to find the directory item you want to erase (p. 49).

```
Helen
1234567890
```

4 Press **INTERCOM/CLEAR**.

```
Clear?
◀=No      ▶=Yes
```

5 Press **FWD/EDIT** (▶) (Yes key) or **INTERCOM/CLEAR**.

```
Clear
```

- The display will show the next item.
- To return to the standby mode, press **FUNCTION/EXIT/CH**.

•You can exit the directory list any time by pressing **FUNCTION/EXIT/CH**.

With the base unit

1 Press **DIRECTORY** to enter the directory list.

- The first item is displayed.

2 Press **SKIP/FF** or **REPEAT/REW** repeatedly to find the directory item you want to erase (p. 50).

```
Helen
1234567890
```

3 Press **ERASE/CLEAR**.

```
Clear?
<<=No    >>=Yes
```

4 Press **SKIP/FF** (Yes key) or **ERASE/CLEAR**.

```
Clear
```

- The display will show the next item.
- To return to the standby mode, press **STOP/EXIT**.

•You can exit the directory list any time by pressing **STOP/EXIT**.

Intercom

A 2-way intercom is possible between the handset and the base unit.

Paging the base unit from the handset

- 1 Handset:
Press **INTERCOM/CLEAR**. Talk to the paged party after the beeps.

- "Intercom" is displayed.

- 2 Base unit:
When the other party's voice is heard, answer using the **MIC**.

- 3 Handset:
To end the intercom, press **INTERCOM/CLEAR**.

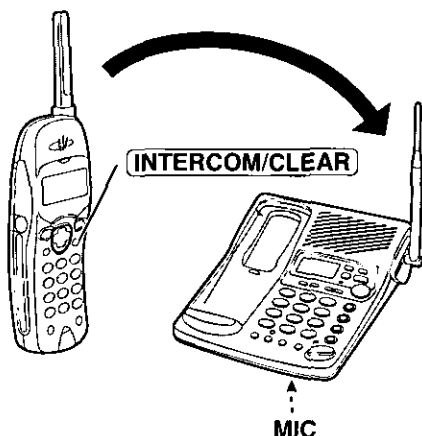

Paging the handset from the base unit (Handset locator)

Using this feature, you can locate a misplaced handset.

- 1 Base unit:
Press **LOCATOR/INTERCOM**.
 - "Paging" is displayed on the base unit.
 - The handset beeps for 1 minute and displays "Paging Press INTERCOM".
 - To stop paging, press **LOCATOR/INTERCOM** again.

- 2 Handset:
Press **INTERCOM/CLEAR** to answer.

- "Intercom" is displayed.

- 3 Base unit:
Talk into the **MIC**.

- 4 Handset:
To end the intercom, press **INTERCOM/CLEAR**.

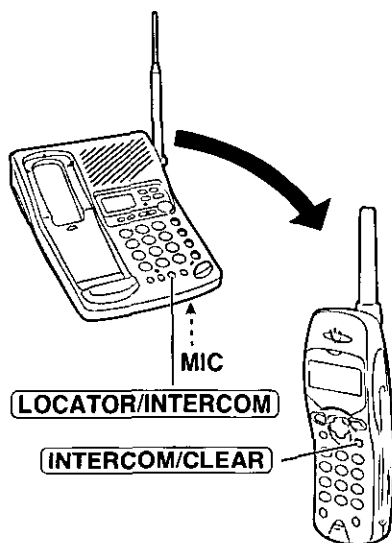

During an intercom call:

- Intercom calls can only be ended with the handset.
- If the handset user has difficulty hearing the base unit user, decrease the base unit speaker volume by pressing **VOLUME** .
- If an incoming call is received, the intercom call stops and the unit starts to ring. To answer, press **TALK** or **DIGITAL SP-PHONE**.

Transferring a Call Using the Intercom

The intercom can be used during a call. This feature enables you to transfer a call between the handset and the base unit.

From the handset to the base unit

- 1 Handset:**
During a call, press **INTERCOM/CLEAR**. Talk to the paged party after the beeps.
 - The call is put on hold and "Intercom hold" is displayed.
 - If the base unit user does not answer, press **TALK**.
- 2 Base unit:**
When the paging party's voice is heard, answer using the **MIC**.
- 3 Base unit:**
To answer the call, press **DIGITAL SP-PHONE**.
 - The transfer is complete.

From the base unit to the handset

- 1 Base unit:**
During a call, press **LOCATOR/INTERCOM**.
 - The call is put on hold and "Paging" is displayed.
 - If the handset user does not answer, press **DIGITAL SP-PHONE**.
- 2 Handset:**
Press **INTERCOM/CLEAR** to answer the page.
- 3 Handset:**
To answer the call, press **TALK**.
 - The transfer is complete.

Special Features

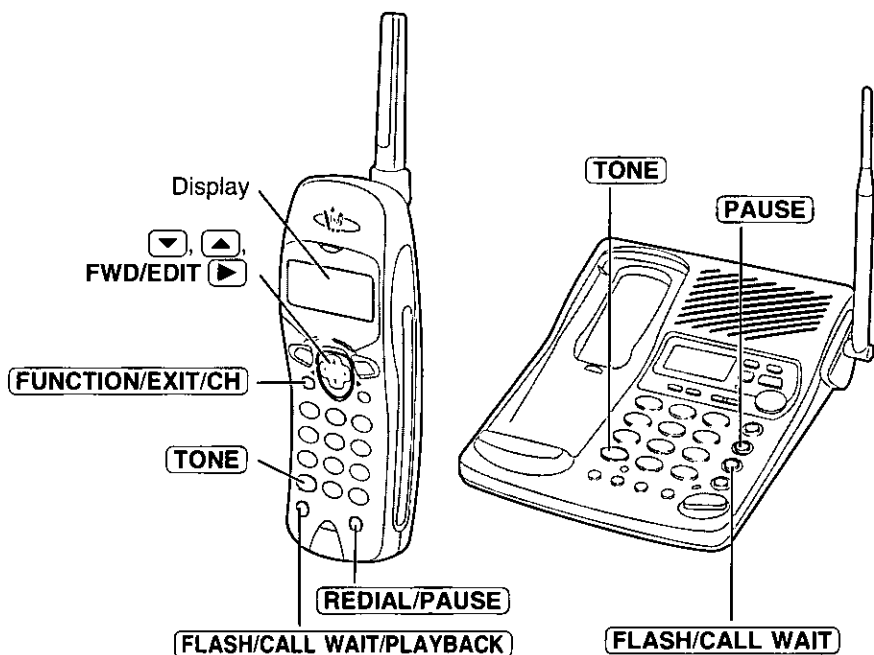

Automatic Security Code Setting

Each time you place the handset on the base unit, the unit automatically selects one of more than a million security codes. These codes help prevent the unauthorized use of your telephone line by another cordless telephone user.

Temporary Tone Dialing (For Rotary or Pulse Service Users)

Press **TONE** before entering access numbers which require tone dialing.

- The dialing mode changes to tone. You can enter numbers to access an answering service, electronic banking service, etc. When you hang up, the mode will return to pulse.
- Access numbers entered after pressing **TONE** will not be included when redialing.



For Call Waiting Service Users

Press **FLASH/CALL WAIT/PLAYBACK** or **FLASH/CALL WAIT** if you hear a call-waiting tone while talking.

- The first call is put on hold and you can answer the second call.
- To return to the first caller, press **FLASH/CALL WAIT/PLAYBACK** or **FLASH/CALL WAIT** again.
- The call waiting service cannot be used when:
 - the answering system is recording someone's message, or
 - a parallel connected telephone is in use.
- If this function does not operate properly, consult your telephone company for details.

Call Waiting Caller ID Feature

Call Waiting Caller ID Feature allows your unit to display the second caller's information. After you hear a call-waiting tone while talking, the unit will display the caller's name with the phone number and "----Waiting----".

NANCY BROWN
1-000-222-3333
----Waiting----

- Please contact your telephone company for details and availability in your area.

Cordless Telephone

How to Use the PAUSE Button (For Analog PBX Line/Long Distance Service Users)

We recommend you press **REDIAL/PAUSE** or **PAUSE** if a pause is required for dialing with a PBX or to access a long distance service.

Ex. Line access number **9** (PBX)

9 → **REDIAL/PAUSE** or **PAUSE** → Phone number

- Pressing **REDIAL/PAUSE** or **PAUSE** once creates a 3.5 second pause. This prevents misdialing when you redial or dial a stored number.
- Pressing **REDIAL/PAUSE** or **PAUSE** more than once increases the length of the pause between numbers.

► Special Features

FLASH Button



Pressing **FLASH/CALL WAIT/PLAYBACK** or **FLASH/CALL WAIT** allows you to use special features of your host PBX such as transferring an extension call or accessing special telephone services (optional) such as call waiting.

Selecting the flash time

The flash time depends on your telephone exchange or host PBX. You can select the following flash times: "700, 600, 400, 300, 250, 110, 100 or 90 ms (milliseconds)". Your phone comes from the factory set to "700 ms".



Make sure the unit is in the standby mode.

1 Press **FUNCTION/EXIT/CH**.

2 Press  or  repeatedly until the arrow points to "Program".

Ringer volume
▶Program
▼▲ ▶=Yes

3 Press **FWD/EDIT**  (Yes key).

4 Press  or  repeatedly until the arrow points to "Set flash time".

Save DIRECT#
▶Set flash time
▼▲ ▶=Yes

5 Press **FWD/EDIT**  (Yes key).

Flash time
: 700ms
▼▲ ▶=Save

6 Press  or  repeatedly until the desired time is displayed.

7 Press **FWD/EDIT**  (Save key).

- A beep sounds.
- To return to the standby mode, press **FUNCTION/EXIT/CH**.

- You can exit the programming mode any time by pressing **FUNCTION/EXIT/CH**.
- If you are connected via a PBX, a longer flash time may be necessary to use PBX functions (transferring a call etc.). Consult your PBX supplier for the correct setting.

Automatic Answering Operation

When the unit answers a call, a greeting message is played and the caller's message is recorded. While recording, "- Answering -" will be displayed.

- The total recording time (including greeting message) is **about 15 minutes**. If messages are recorded in noisy rooms, the time may be shortened by up to 3 minutes.
- A maximum of 64 messages (including greeting message) can be recorded.

Setting the Unit to Answer Calls

Press **ANSWER ON** to turn on the answering system.

- The indicator lights and "Answer set" is heard.
- The unit will announce the remaining recording time if it is less than 5 minutes.
- If you hear "Memory full", "Message full" is displayed on the base unit and the ANSWER ON indicator flashes rapidly, erase some, or all, of the messages (p. 63).

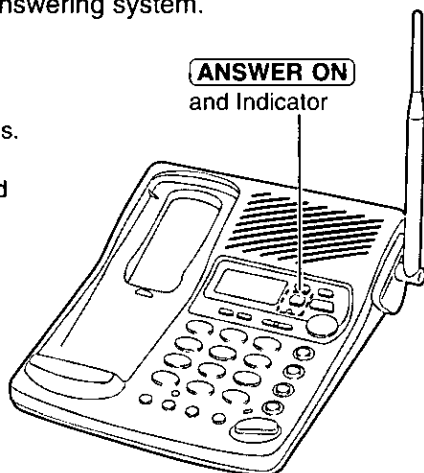

Answering System

- If you do not want the unit to answer calls, press **ANSWER ON** again to turn off the answering system. The indicator light goes out and "Answer off" is heard.
- You can also turn on the answering system remotely using any other phone (p. 75).

Monitoring incoming calls

While a call is being recorded, you can monitor it through the speaker. To answer the call with the speakerphone, press **DIGITAL SP-PHONE**. For the handset, lift the handset off the base unit and press **TALK**. The unit stops recording.

Listening to Messages

You can see the total number of recorded messages on the base unit display. If the ANSWER ON indicator flashes, new messages have been recorded.

Listening to only new messages

Press **NEW MESSAGE** briefly.

- The unit announces the number of new messages and plays them back.

Listening to all recorded messages

Press and hold **NEW MESSAGE** until playback starts.

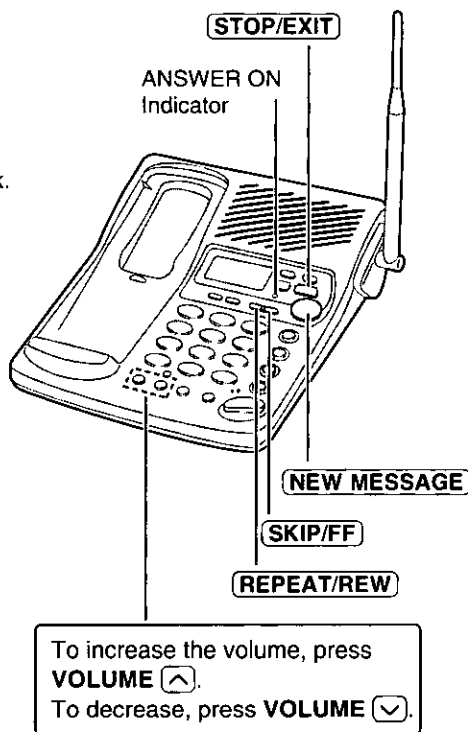

- During playback, the display shows which message is being played. (Ex. While the first message is being played back, "Message 1" is displayed.)
- At the end of the last message, "End of final message" is heard. The unit will announce the remaining recording time if it is less than 5 minutes.



During playback

To repeat/
rewind
message

To repeat from the beginning of the message

Press **REPEAT/REW** briefly.

- If you press within 5 seconds of playback, the previous message will be played.

To rewind part of the message

Press and hold **REPEAT/REW** until you reach the desired place.

- At the beginning of the message, 3 beeps will sound.

To skip/cue
message

To skip to the next message

Press **SKIP/FF** briefly.

To cue to part of the message

Press and hold **SKIP/FF** until you reach the desired place.

- The message will be heard at twice the normal speed.
- At the end of the message, 3 beeps will sound.

To stop
operation

Press **STOP/EXIT**.

- To resume playback, press **NEW MESSAGE**.

- If you do not press any button for 60 seconds or if you press **STOP/EXIT** again, the unit will return to the standby mode.

For Caller ID service users (p. 34)

- During playback, the base unit display will show the name and/or number of the caller whose message is being played.

To call back the displayed number:

During playback, lift the handset and press **TALK** within 10 seconds, or press **DIGITAL SP-PHONE**.

—The unit stops playback and automatically dials the displayed phone number.

- After listening to new incoming messages, “√” will be added to the call entries in the Caller ID Caller List (p. 37).

► Listening to Messages

From the Handset

If someone else is in the room and you want to listen to the recorded messages privately, you can use the handset.

- 1 Handset:
Press **FLASH/CALL WAIT/PLAYBACK**.
 - The number of new messages is heard on the handset.

- 2 Base unit:
To listen to new messages, press **NEW MESSAGE** briefly. To listen to all messages, press and hold **NEW MESSAGE** until playback starts.
 - The messages will be heard on the handset.
 - REPEAT/REW**, **SKIP/FF** and **STOP/EXIT** can also be used during playback (p. 61).



- 3 When finished, press **FLASH/CALL WAIT/PLAYBACK** or place the handset on the base unit.

- You can also listen to messages without using the base unit. See page 76.

Erasing Messages

The unit will announce the remaining recording time after playback, if it is less than 5 minutes. New messages cannot be recorded when:

- “Memory full” is heard.
- “Message full” is displayed on the base unit.
- the ANSWER ON indicator flashes rapidly.

Erase some, or all, of the messages. We recommend you erase unnecessary messages after each playback.

Erasing a specific message

Press **ERASE/CLEAR** while the message you want to erase is being played.

- The unit erases the message.
- A short beep will sound and the unit will continue to play the next message.

Erasing all messages

All recorded messages, except the greeting message, can be erased at one time.

- 1 Press **ERASE/CLEAR**.
 - “Press ERASE again to erase all messages” is heard.
- 2 Within 5 seconds, press **ERASE/CLEAR** again.
 - A beep sounds and “No messages” is heard.
 - The base unit display shows “0 message”.

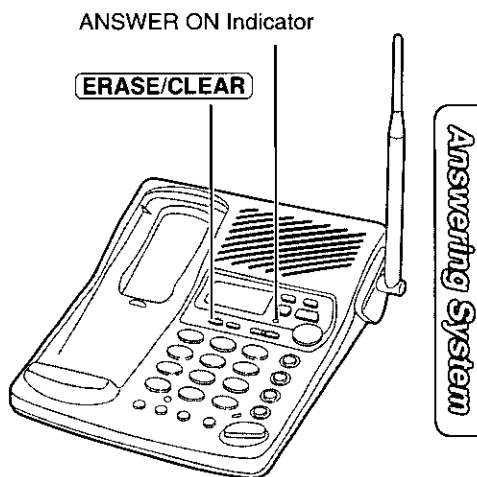

- The information in the Caller List will not be erased. To erase Caller List information, see page 41.

Pager Call

This feature allows you to alert your pager when the unit records an incoming message or receives a Caller ID call (p. 68). You can retrieve the message from a touch tone telephone (p. 70). If you subscribe to a Caller ID service, the caller's telephone number will be displayed on your pager. First program the following settings (p. 64–68), then set the unit to call the pager.

Make sure that the unit is in the standby mode.

Storing a Pager Number

If you use a 1-800 pager number, see the next page for storing the pager number.

1 Press **FUNCTION/EXIT/CH**.

2 Press **▼** or **▲** repeatedly until the arrow points to "Program".

Ringer volume
▶Program
▼▲ ▶=Yes

3 Press **FWD/EDIT** **▶** (Yes key).

▶Save DIRECT#
Set flash time
▼▲ ▶=Yes

4 Press **▼** or **▲** repeatedly until the arrow points to "TAD program".

Talk switching
▶TAD program
▼▲ ▶=Yes

5 Press **FWD/EDIT** **▶** (Yes key).
●The base unit display shows the answering system function menu.

Answering system setting.
See base unit.

6 Press **#**.

Base unit display

Enter pager no.

7 Enter your pager number, and press **REDIAL/PAUSE** twice.* Enter the access code, if required by your pager company, and press **REDIAL/PAUSE** twice again.*

- The entered number is displayed on the base unit.
- If you misdial, press **INTERCOM/CLEAR** and enter the correct number.
- You can enter a total of 44 digits.



8 Press **FWD/EDIT**  (Save key).

- A beep sounds.
- To return to the standby mode, press **FUNCTION/EXIT/CH**.

* Pager companies require a delay after the pager number and/or the access code is dialed. Contact your pager company regarding the required pause time. Pressing **REDIAL/PAUSE** once creates a 3.5 second delay and counts as one digit.

- If the line has rotary or pulse service, press **TONE** between the pager number and **REDIAL/PAUSE** in step 7.

Storing a 1-800 pager number

If you use a 1-800 pager number with a PIN code, store the pager number as follows.

1 Repeat steps 1 through 6 on page 64.

2 ① Enter the 1-800 pager number, and press **REDIAL/PAUSE** 3 times.*

② Enter the PIN code, and press **REDIAL/PAUSE** twice.*

- The entered number is displayed on the base unit.
- If you misdial, press **INTERCOM/CLEAR** and enter the correct number.
- You can enter a total of 44 digits.

3 Press **FWD/EDIT**  (Save key).

- A beep sounds.
- To return to the standby mode, press **FUNCTION/EXIT/CH**.

* Pager companies require a delay after the pager number and the PIN code are dialed. Contact your pager company regarding the required pause time. Pressing **REDIAL/PAUSE** once creates a 3.5 second delay and counts as one digit.

- If the line has rotary or pulse service, press **TONE** between the pager number and **REDIAL/PAUSE** in step 7.

• Alphanumeric voice dispatch pager services will not work with this function.

► Pager Call

Storing Your Home Telephone Number

After storing your home telephone number, it will then be displayed on your pager when your family wants you to call home. (See useful information on page 67.)

1 Press **FUNCTION/EXIT/CH**.

2 Press **▼** or **▲** repeatedly until the arrow points to "Program".

Ringer volume
▶Program
▼▲ ▶=Yes

3 Press **FWD/EDIT** **▶** (Yes key).

▶Save DIRECT#
Set flash time
▼▲ ▶=Yes

4 Press **▼** or **▲** repeatedly until the arrow points to "TAD program".

Talk switching
▶TAD program
▼▲ ▶=Yes

5 Press **FWD/EDIT** **▶** (Yes key).

- The base unit display shows the function menu for the answering system.

Answering system setting.
See base unit.

6 Press **7**.

Base unit display

Enter home no.

7 Enter your home telephone number up to 11 digits.

- The entered number is displayed on the base unit.
- If you misdial, press **INTERCOM/CLEAR** and enter the correct number.

8 Press **FWD/EDIT** **▶** (Save key).

- A beep sounds.
- To return to the standby mode, press **FUNCTION/EXIT/CH**.

- Your pager will also display your home number if the unit receives a call from an area which does not provide the Caller ID service or the caller requests not to show their information. Please call home to check who alerted your pager.



To confirm the stored pager and home numbers

1. Press **FUNCTION/EXIT/CH**.
2. Press **▼** or **▲** to select "Calling pager".
3. Press **FWD/EDIT** **▶** (Yes key).
4. Press **TALK**.

- The unit dials the stored pager number.
- The pager beeps, and displays your home number and "11".
- If the pager does not beep or does not display your home number and "11", store the pager and home numbers again (p. 64–66).

Useful Information

Your family can let you know when they want you to call home by pressing **FUNCTION/EXIT/CH** **→** **▼** or **▲** to select "Calling pager" **→** **FWD/EDIT** **▶** (Yes key) **→** **TALK**.

* What "11" means

When your unit alerts your pager, "11" will be displayed after the caller's telephone number. "11" will not be displayed when another phone alerts your pager.

Ex. When the unit records a caller's message whose number is "2345678":
"234567811" will be displayed on your pager. If you select pager mode "2" (p. 68) and a caller does not leave a message, "00" will be displayed instead of "11".

Ex. When the caller whose number is "2345678" alerts your pager directly:
"2345678" will be displayed on your pager.

To erase the stored pager number

Repeat steps 1 through 6 on page 64. **→** **INTERCOM/CLEAR** **→**
→ **FWD/EDIT** **▶** (Save key) **→** **FUNCTION/EXIT/CH**.

- The pager call mode will automatically return to OFF (p. 69).

To erase the stored home telephone number

Repeat steps 1 through 6 on page 66. **→** **INTERCOM/CLEAR** **→**
→ **FWD/EDIT** **▶** (Save key) **→** **FUNCTION/EXIT/CH**.

► Pager Call

Pager Mode Setting

After subscribing to a **Caller ID service** (p. 34), you can select one of the following pager mode settings. The unit will alert your pager:

Recorded MSG: After the unit records an incoming message (factory preset),

OR

Received call: Each time the unit receives a Caller ID call, even if the caller does not leave a message.

If you want to change the mode, proceed as follows.

1 Press **FUNCTION/EXIT/CH**.

2 Press **▼** or **▲** repeatedly until the arrow points to "Program".

Ringer volume
▶Program
▼▲ ▶=Yes

3 Press **FWD/EDIT** **▶** (Yes key).

▶Save DIRECT#
Set flash time
▼▲ ▶=Yes

4 Press **▼** or **▲** repeatedly until the arrow points to "TAD program".

Talk switching
▶TAD program
▼▲ ▶=Yes

5 Press **FWD/EDIT** **▶** (Yes key).

- The base unit display shows the answering system function menu.

Answering system setting.
See base unit.

6 Press **6**.

- The current setting is displayed on the base unit.

Base unit display

Pager mode
:Recorded MSG

7 To select "**Received call**", press **2**.

OR

To select "**Recorded MSG**", press **1**.

8 Press **FWD/EDIT** **▶** (Save key).

- A beep sounds.
- To return to the standby mode, press **FUNCTION/EXIT/CH**.

- If you select "**Received call**" and set the unit to call your pager (p. 69), the unit will alert your pager even if the answering system is not turned on.
- Even if you select "**Received call**", the unit will not alert your pager when a Caller ID call which does not have a phone number is received and the caller does not leave any message.

Setting the Unit to Call a Pager

- 1 Press **FLASH/CALL WAIT/PLAYBACK**.
 - The number of new messages is heard on the handset.
- 2 Press **3**.
 - “ **PAGER** ” is displayed on the base unit.
 - If “ **PAGER** ” is not displayed, the pager number has not been stored. Store the number (p. 64, 65), and try again.
- 3 Press **FLASH/CALL WAIT/PLAYBACK**.

To turn off the pager call mode, repeat steps 1 through 3.

- “ **PAGER** ” will disappear.
- Each time you press **3** in step 2, the mode will turn on or off.

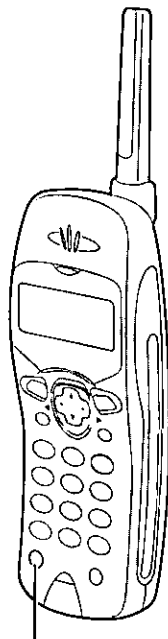

FLASH/CALL WAIT/PLAYBACK

Answering System

If you have not subscribed to a Caller ID service, the caller's telephone number will not be displayed on your pager.

- If another message (or Caller ID call) is received before the unit alerts your pager for a previous message (or Caller ID call), the previous caller information will not be sent to your pager. Only the last call received will be sent to your pager.
- If someone else makes or answers another call with the unit or a parallel connected phone before the unit alerts your pager for a previous message (or Caller ID call), the unit will stop alerting your pager for that message (or Caller ID call).
- If you receive a telephone number on your pager but cannot recognize the caller, you may have received a direct inward dial (DID) call, such as from a PBX. Please call your unit to check the caller's message.

Remote Operation from a Touch Tone Phone

You can operate the answering system from any touch tone phone. A synthesized voice menu will guide you on how to operate the unit (p. 72).

- To skip the voice menu and operate the unit directly, see page 74.

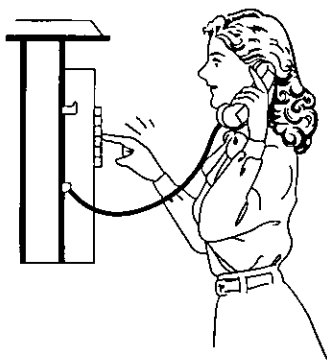

Summary of remote operation

Call your unit from a touch tone phone.



Enter your remote code (p. 71) during or after the greeting message.
•The number of new messages is heard.



After 3 seconds, the voice menu will start (p. 72).
Follow the menu or enter the direct commands (p. 74).



To end remote operation, hang up.
•The messages are saved.

- The unit will announce the remaining recording time after playback, if it is less than 5 minutes.



Setting the Remote Code

The remote code prevents unauthorized people from accessing your unit and listening to your messages. Choose any **2-digit number (00–99)**. The factory preset remote code is "11". If you do not program your own remote code, you can use "11".

Make sure that the unit is in the standby mode.

1 Press **FUNCTION/EXIT/CH**.

2 Press or repeatedly until the arrow points to "Program".

Ringer volume
▶Program
▼▲ ▶=Yes

3 Press **FWD/EDIT** (Yes key).

▶Save DIRECT#
Set flash time
▼▲ ▶=Yes

4 Press or repeatedly until the arrow points to "TAD program".

Talk switching
▶TAD program
▼▲ ▶=Yes

5 Press **FWD/EDIT** (Yes key).
•The base unit display shows the function menu for the answering system.

Answering system setting.
See base unit.

6 Press **1**.
•The current remote code is displayed on the base unit.

Base unit display
Remote code :11

7 Enter a remote code using a **2-digit number (00–99)**.

8 Press **FWD/EDIT** (Save key).
•A beep sounds.
•To return to the standby mode, press **FUNCTION/EXIT/CH**.

•If 6 beeps sound during programming, a wrong key was pressed. Enter the correct number.

To check the remote code

Repeat steps 1 to 6.

•The current remote code is displayed on the base unit. When finished, press **FUNCTION/EXIT/CH**.

Answering System

Remote Operation from a Touch Tone Phone

Voice Menu

The shaded boxes are voice prompts.

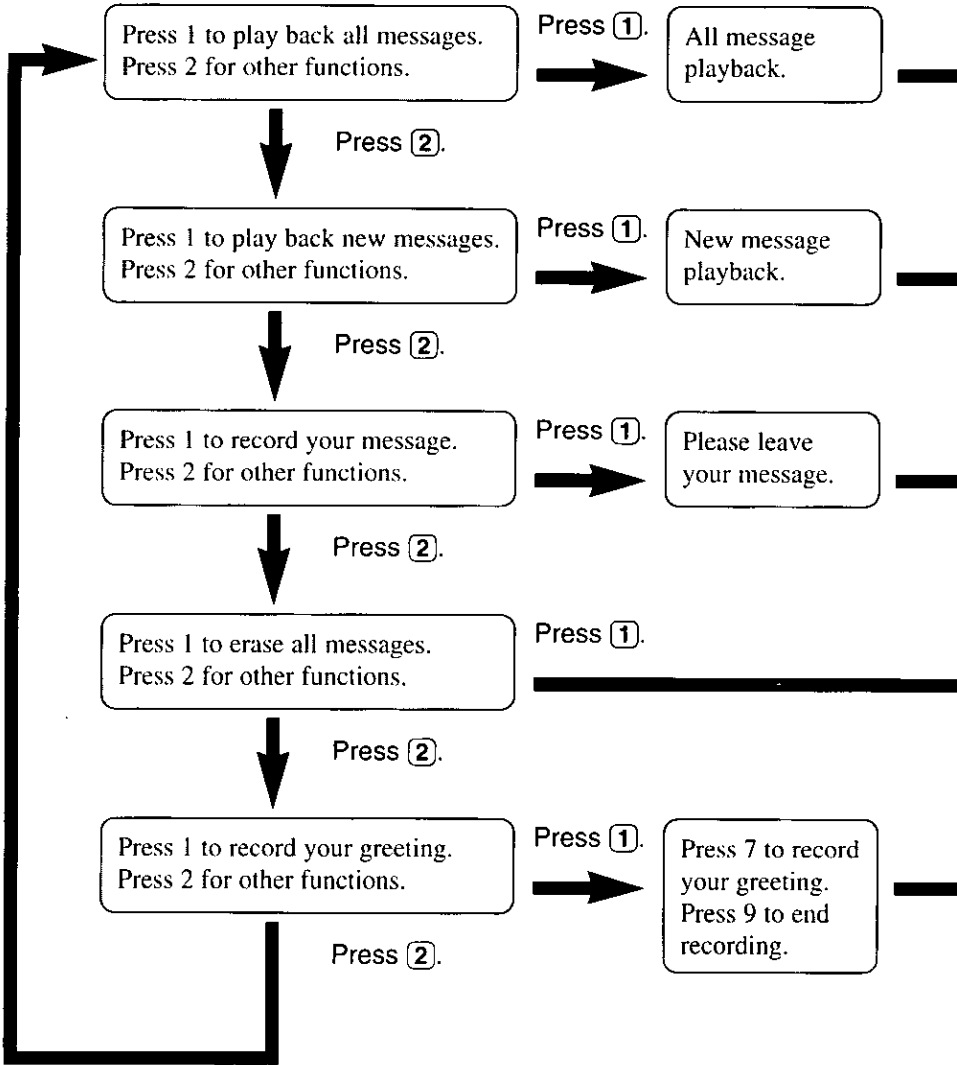



All Message Playback

All recorded messages are played back. At the end of the last message, "End of final message" is heard. The unit will announce the remaining recording time if it is less than 5 minutes.

New Message Playback

Only new messages are played back. At the end of the last message, "End of final message" is heard. The unit will announce the remaining recording time if it is less than 5 minutes.

Recording a Memo Message

You can leave a personal message.

1. Talk after you hear "Please leave your message".
2. When you finish recording, hang up.

Erasing All Messages

All recorded messages (except greeting message) are erased.

Recording a Greeting Message

You can re-record your greeting message.

1. Press **7**.
You will hear a voice prompt followed by a long beep.
2. After the beep, talk for up to 2 minutes.
3. When you finish recording, press **9**.
4. Your greeting will be played back for confirmation.

- 3 seconds after playback, the voice menu will start again from the beginning.
- If you hear "Memory full" after playback, erase some, or all, of the messages (p. 74).

► Remote Operation from a Touch Tone Phone

Direct Remote Operation

Once you have entered the remote code, you can also control your unit by direct commands instead of using the voice menu. To end the remote operation, hang up anytime.

Direct commands

NEW MESSAGE
PLAYBACK

4

- Only new messages are played back.
-

ALL MESSAGE
PLAYBACK

5

- All messages are played back.
-

REPEAT
(During playback)

1

- The current message is repeated.
-

SKIP
(During playback)

2

- The current message is skipped.
The next message is played.
-

STOP

9

- Operation is stopped temporarily.
 - To resume operation, enter a direct command within 15 seconds, or the voice menu will start.
-

GREETING
MESSAGE
RECORDING

7

- A long beep sounds.

↓
RECORD

- After the beep, talk immediately for up to 2 minutes.

↓
9

- The recording is stopped.
 - The recorded message is played.
-

ERASING A
SPECIFIC
MESSAGE
(During playback)

* 4

- The current message is erased.
 - A short beep will sound and the next message will be played.
-

ERASING ALL
MESSAGES

* 5

- All recorded messages are erased.
 - A long beep sounds and "No messages" is heard.
-

PAGER CALL
ON/OFF

3

- Each time you press **3**, "On/Off" is heard and the mode will turn on or off.
- If you have not stored a pager number, 6 beeps will sound and the mode will not turn on.

ANSWERING
SYSTEM OFF

0

- The unit hangs up and will not answer calls until turned on again.
-

Turning on the answering system

Call your unit and wait for 15 rings.

- The unit will answer and the greeting message will be played.
- The answering system will turn on. Hang up or enter the remote code for other options.
- When turning on the answering system using a rotary or pulse service telephone, you cannot enter the remote code for other options.

Skipping the greeting message

After calling your unit, press ***** during the greeting message.

- The unit skips the rest of the greeting message and you can start recording your message after the long beep.

Remote Operation with the Handset

You can operate your answering system with the handset.

The announcements and recorded messages can only be heard with the handset.

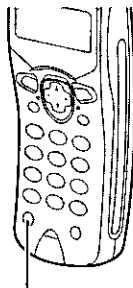

FLASH/CALL WAIT/PLAYBACK

Summary of remote operation

Press **FLASH/CALL WAIT/PLAYBACK**.

- The number of new messages is heard.
- "Remote operation" is displayed on the handset.



Enter the desired direct commands (p. 77).

- If you do not enter a command, the voice menu will start (see below).
- After the voice menu, all message playback will start.



To end remote operation, press **FLASH/CALL WAIT/PLAYBACK**.

- The messages are saved.

- The unit will announce the remaining recording time after playback, if it is less than 5 minutes.
- If the unit starts to ring during the remote operation, press **TALK** to answer the call. The remote operation is ended.
- If you hear "Memory full" after playback, erase some, or all, of the messages (p. 77).

Voice menu

If no commands are entered after you press **FLASH/CALL WAIT/PLAYBACK**, the unit will start the following voice menu.

"Press 4 to play back new messages. Press 5 to play back all messages."

- You can enter direct commands even if the voice menu has started.

Direct commands

NEW MESSAGE PLAYBACK	4	<ul style="list-style-type: none">• Only new messages are played back.
ALL MESSAGE PLAYBACK	5	<ul style="list-style-type: none">• All messages are played back.
REPEAT (During playback)	1	<ul style="list-style-type: none">• The current message is repeated.
SKIP (During playback)	2	<ul style="list-style-type: none">• The current message is skipped. The next message is played.
STOP	9	<ul style="list-style-type: none">• Operation is stopped temporarily.• To resume operation, enter a direct command within 15 seconds, or the voice menu will start (p. 76).
ERASING A SPECIFIC MESSAGE (During playback)	* 4	<ul style="list-style-type: none">• The current message is erased.• A short beep will sound and the next message will be played.
ERASING ALL MESSAGES	* 5	<ul style="list-style-type: none">• All recorded messages are erased.• A long beep sounds and "No messages" is heard.
PAGER CALL ON/OFF	3	<ul style="list-style-type: none">• Each time you press 3, the mode will turn on or off.• If you have not stored a pager number, "PAGER" will not be displayed on the base unit, and the mode will not turn on.
ANSWERING SYSTEM OFF	0	<ul style="list-style-type: none">• "Answer off" is heard and the answering system is turned off.
ANSWERING SYSTEM ON	8	<ul style="list-style-type: none">• "Answer set" is heard and the answering system is turned on.

Wall Mounting

This unit can be mounted on a wall phone plate.

- 1 Set the handset holder as shown.

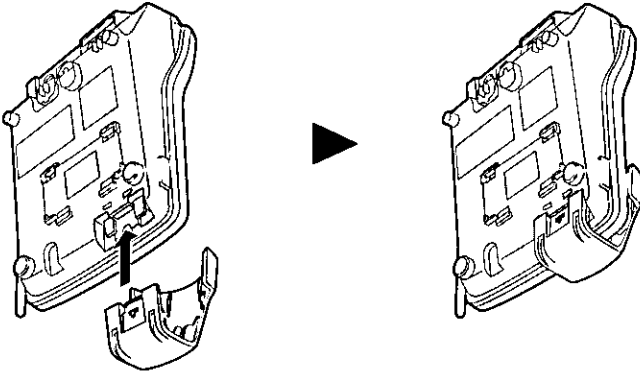

- 2 Connect the AC adaptor.

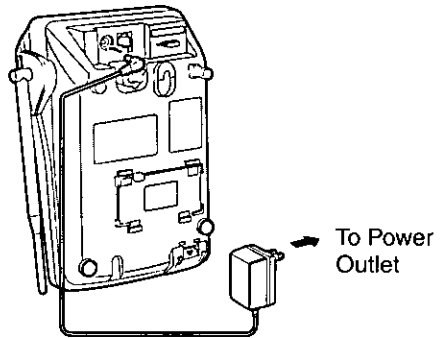

- 3 Tuck the telephone line cord inside the wall mounting adaptor, then push it in the direction of the arrow.

•The word "UP" should face upward.

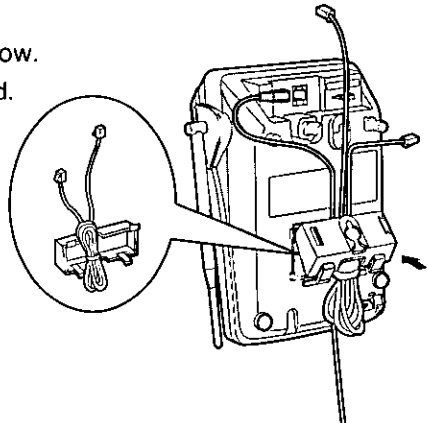

4 Connect the telephone line cord.
Mount the unit, then slide down.

- Raise the antenna.

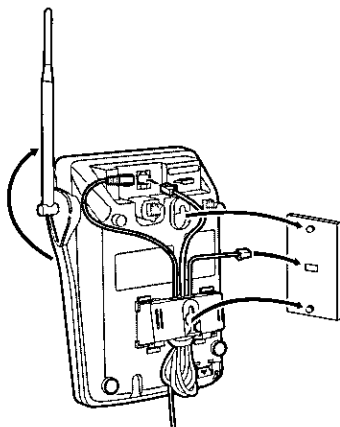

5 **To charge the battery:**
Place the handset on the
handset holder as shown.

- The IN USE/CHARGE
indicator lights.

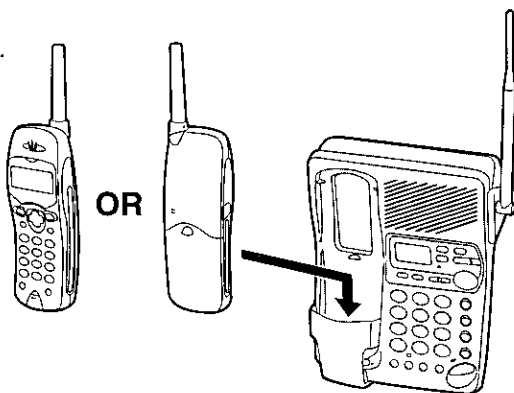

To remove the handset holder

While pressing the arrow (①) and opposite side (②) of the holder, pull out the handset holder.

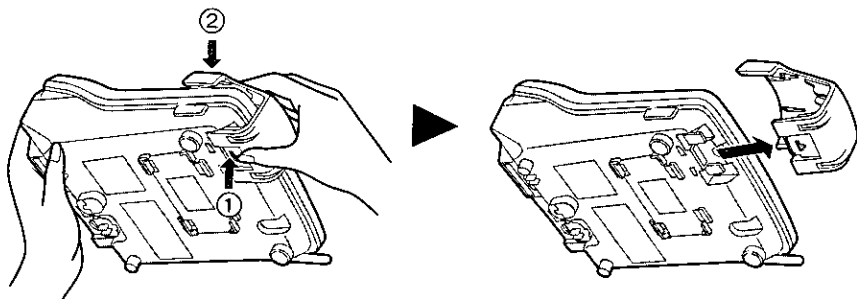

Useful Information

Using the Belt Clip

You can hang the handset on your belt or pocket using the belt clip.

To attach the belt clip

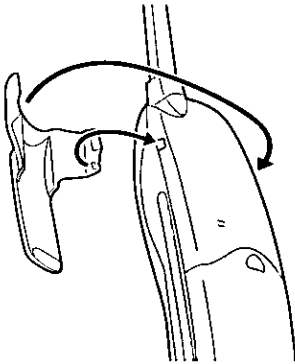

To remove the belt clip



Using the Headset

Plugging the headset into the handset allows a hands-free phone conversation.

For KX-TC1871B and KX-TC1872B users

Please purchase a Panasonic KX-TCA87 or KX-TCA90 headset.

For headset order and information, call the accessories telephone number on page 2.

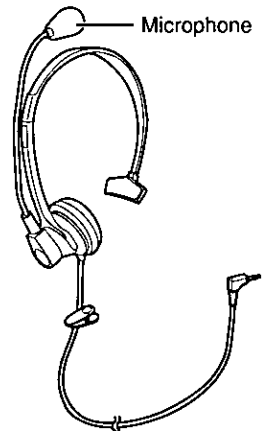

Connecting the headset to the handset

Open the headset jack cover, and connect the headset to the headset jack as shown below.

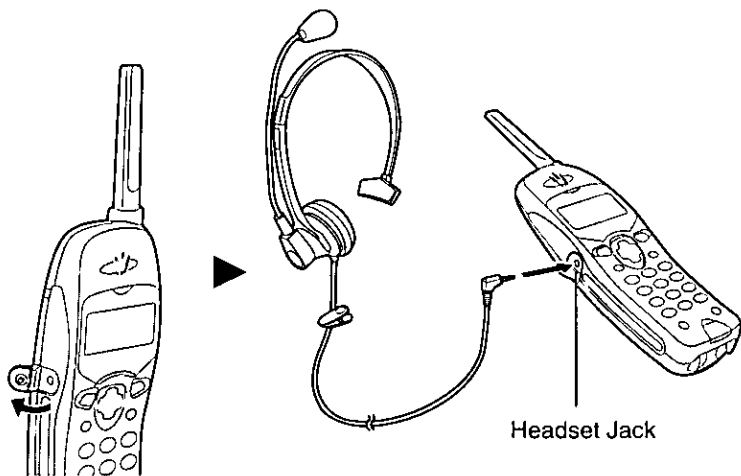

When the headset is connected to the handset, make sure to use the headset to talk with the caller. If you want to have a normal cordless phone conversation, disconnect the headset.

How to wear the headset

- 1 Place the headset on your head and attach the clothing clip to the desired position.
- 2 Adjust the microphone to a comfortable position.
 - Place the microphone near your mouth.



Battery Replacement

If "Recharge battery" is displayed and/or "[■]" flashes after being fully charged, replace the battery with a new Panasonic P-P508 battery. To order, call the accessories telephone number on page 2.

- 1 Press the notch on the battery cover firmly and slide it as indicated by the arrow.
- 2 Replace the battery and close the cover.
- 3 Make sure you charge the new battery for about 6 hours in order to display the battery strength prompt correctly (p. 14).

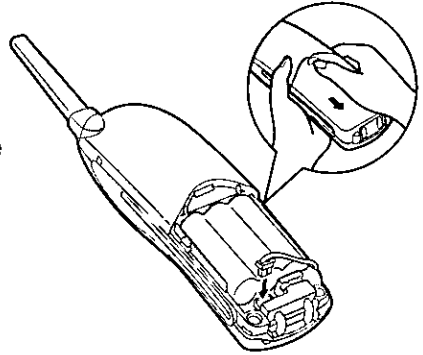

Attention:

The product you have purchased is powered by a nickel cadmium battery which is recyclable. At the end of its useful life, under various state and local laws, it is illegal to dispose of this battery into your municipal waste stream. Please call 1-800-8-BATTERY for information on how to recycle this battery.



Adding Another Phone

This unit will not function during a power failure. To connect a standard telephone on the same line, use the Panasonic T-adaptor KX-J66. To order, call the accessories telephone number on page 2.

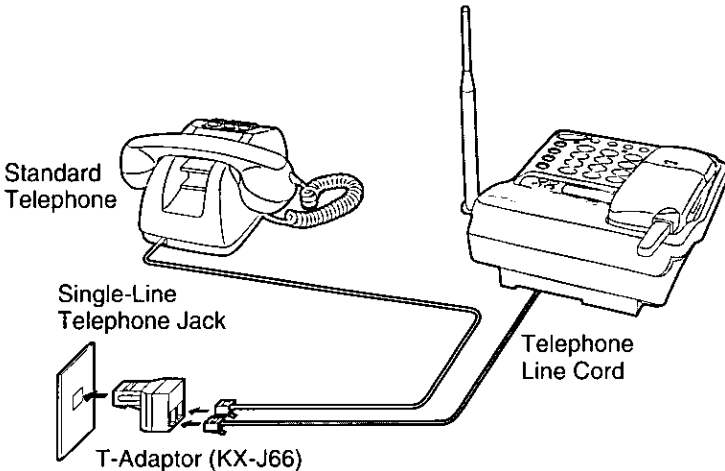

Before Requesting Help



Cordless Telephone

Problem	Remedy
"No link to base. Place on cradle and try again." is displayed and an alarm tone sounds.	<ul style="list-style-type: none">• You are too far from the base unit. Move closer and try again.• Place the handset on the base unit and try again.• Plug in the AC adaptor.• Raise the base unit antenna.
Static, sound cuts in/out, fades. Interference from other electrical units.	<ul style="list-style-type: none">• Locate the handset and the base unit away from other electrical appliances (p. 3).• Move closer to the base unit.• Raise the base unit antenna.• Press FUNCTION/EXIT/CH to select a clearer channel.
The handset and/or the base unit do not ring.	<ul style="list-style-type: none">• The ringer volume is set to OFF. Set to HIGH or LOW (p. 20).• If the line is connected to a low voltage system such as a PBX, the unit may not ring. Set the line mode to "B" (p. 17).
The handset display is blank.	<ul style="list-style-type: none">• The handset is in the standby mode (p. 15). Press ▼, ▲, BACK ◀ or FWD/EDIT ▶ to turn the display on.
The handset display is still blank after pressing ▼ , ▲ , BACK ◀ or FWD/EDIT ▶ .	<ul style="list-style-type: none">• Charge the battery fully (p. 14).
You cannot store a name and phone number in the directory.	<ul style="list-style-type: none">• You cannot store an item in the directory while the unit is in the talk, speakerphone or intercom mode, or while the answering system is in use.• Do not pause for over 60 seconds while storing.
While programming or searching, the unit starts to ring and stops the program/search.	<ul style="list-style-type: none">• To answer the call, press TALK or DIGITAL SP-PHONE. Start again from the beginning after hanging up.

► Before Requesting Help

Problem	Remedy
The unit does not display the caller's name and/or phone number.	<ul style="list-style-type: none">• You do not subscribe to a Caller ID service.• Other telephone equipment may be interfering with your phone. Disconnect it and try again.• Other electrical appliances connected to the same outlet may be interfering with the Caller ID information.• Telephone line noise may be affecting the Caller ID information.
The handset display goes to the standby mode while viewing the Caller List.	<ul style="list-style-type: none">• Do not pause for over 60 seconds while searching.• DIGITAL SP-PHONE was pressed.
When a second call is received during a conversation, the unit does not display the new caller's name and/or phone number.	<ul style="list-style-type: none">• The line mode selection is incorrect. See page 17.
LOCATOR/INTERCOM does not function.	<ul style="list-style-type: none">• The handset is too far from the base unit.• The handset is engaged in an outside call or is viewing the Caller List/directory list. Wait until the IN USE/CHARGE indicator light goes out.
You cannot redial by pressing REDIAL/PAUSE or REDIAL .	<ul style="list-style-type: none">• If the last number dialed was more than 32 digits long, the number will not be redialed correctly.• Access numbers entered after pressing TONE will not be included when redialing.
You cannot have a conversation using the handset.	<ul style="list-style-type: none">• When the headset is connected (p. 80), you must use the headset to talk with the caller. To have a normal cordless phone conversation, disconnect the headset.
You cannot have a conversation using the headset.	<ul style="list-style-type: none">• Make sure that the headset is connected properly (p. 80).



Answering System

Problem	Remedy
The answering system is on, but incoming messages are not recorded.	<ul style="list-style-type: none">●The recording time is set to "Greeting only". Select "1 minute" or "3 minutes" (p. 26).●Memory is full. Erase some, or all, of the messages (p. 63).
You cannot listen to the recorded messages.	<ul style="list-style-type: none">●Make sure that the unit is in the stand-by mode.
"Message full" is displayed and the ANSWER ON indicator flashes rapidly, and no new messages are recorded.	<ul style="list-style-type: none">●Memory is full. Erase some, or all, of the messages (p. 63).
You cannot operate the answering system at the base unit.	<ul style="list-style-type: none">●The handset user is operating the answering system. Wait until the IN USE/CHARGE indicator light goes out.
You cannot operate the answering system from a touch tone phone.	<ul style="list-style-type: none">●Make sure you enter the correct remote code.●The answering system may not respond if the tones are too short to activate the unit. Press each button firmly.●The answering system is off. Turn it on (p. 75).
You cannot operate the answering system with the handset.	<ul style="list-style-type: none">●Someone is operating the answering system.●You are too far from the base unit. Move closer to the base unit.●The unit is recording a message. To answer the call, press TALK.





Useful Information

► Before Requesting Help

Problem	Remedy
While recording a greeting message, the unit starts to ring and stops recording.	<ul style="list-style-type: none">● To answer the call, press DIGITAL SP-PHONE, or lift the handset off the base unit or press TALK. Start again from the beginning after hanging up.
During playback, the unit starts to ring and stops playback.	<ul style="list-style-type: none">● To answer the call, press DIGITAL SP-PHONE, or lift the handset off the base unit or press TALK. To resume playback, press NEW MESSAGE after hanging up.
The unit does not alert your pager.	<ul style="list-style-type: none">● The line mode selection is incorrect. See page 17.

General

Problem	Remedy
The unit does not work.	<ul style="list-style-type: none">● Check the settings (p. 13–17).● Charge the battery fully (p. 14).● Clean the charge contacts and charge again (p. 15).● Install the battery properly (p. 14, 82).● Place the handset on the base unit and unplug the AC adaptor to reset. Plug in, and try again.

Problem	Remedy
You cannot program items, such as the dialing mode.	<ul style="list-style-type: none"> ● Programming is not possible while the unit is in the talk or speakerphone mode, when viewing the Caller List/directory list, or while the answering system is in use. ● Do not pause for over 60 seconds while programming. ● Move closer to the base unit. ● , , BACK  or FWD/EDIT  may have been pressed when you picked up the handset. Press FUNCTION/EXIT/CH and try again.
Previously programmed information is erased.	<ul style="list-style-type: none"> ● If a power failure occurs, programmed information may be erased. Reprogram if necessary.
"Recharge battery" is displayed, "{ ■}" flashes or the unit beeps intermittently.	<ul style="list-style-type: none"> ● Charge the battery fully (p. 14).
You charged the battery fully, but "Recharge battery" is still displayed and/or "{ ■}" continues to flash.	<ul style="list-style-type: none"> ● Clean the charge contacts and charge again (p. 15). ● Install a new battery (p. 82).
The IN USE/CHARGE indicator light does not go out while charging.	<ul style="list-style-type: none"> ● This is normal.
If you cannot solve your problem.	<ul style="list-style-type: none"> ● Call our customer call center at 1-800-211-PANA(7262). ● Panasonic's e-mail address for customer inquiries: consumerproducts@panasonic.com for customers in the USA or Puerto Rico ONLY

Important Safety Instructions

When using this unit, basic safety precautions should always be followed to reduce the risk of fire, electric shock, or personal injury.

1. Read and understand all instructions.
2. Follow all warnings and instructions marked on this unit.
3. Unplug this unit from AC outlets before cleaning. Do not use liquid or aerosol cleaners. Use a damp cloth for cleaning.
4. Do not use this unit near water, for example, near a bathtub, washbowl, kitchen sink, or the like.
5. Place this unit securely on a stable surface. Serious damage and/or injury may result if the unit falls.
6. Do not cover slots and openings on the unit. They are provided for ventilation and protection against overheating. Never place the unit near radiators, or in a place where proper ventilation is not provided.
7. Use only the power source marked on the unit. If you are not sure of the type of power supplied to your home, consult your dealer or local power company.
8. Do not place objects on the power cord. Install the unit where no one can step or trip on the cord.
9. Do not overload wall outlets and extension cords. This can result in the risk of fire or electric shock.
10. Never push any objects through slots in this unit. This may result in the risk of fire or electric shock. Never spill any liquid on the unit.
11. To reduce the risk of electric shock, do not disassemble this unit. Take the unit to an authorized servicer when service is required. Opening or removing covers may expose you to dangerous voltages or other risks. Incorrect reassembly can cause electric shock when the unit is subsequently used.
12. Unplug this unit from the wall outlet and refer servicing to an authorized servicer when the following conditions occur:
 - A. When the power supply cord or plug is damaged or frayed.
 - B. If liquid has been spilled into the unit.
 - C. If the unit has been exposed to rain or water.
 - D. If the unit does not work normally by following the operating instructions. Adjust only controls covered by the operating instructions. Improper adjustment may require extensive work by an authorized servicer.
 - E. If the unit has been dropped or physically damaged.
 - F. If the unit exhibits a distinct change in performance.
13. During thunderstorms, avoid using telephones except cordless types. There may be a remote risk of an electric shock from lightning.
14. Do not use this unit to report a gas leak, when in the vicinity of the leak.

SAVE THESE INSTRUCTIONS

CAUTION:

To reduce the risk of fire or injury to persons, read and follow these instructions.

1. Use only the battery(ies) specified.
2. Do not dispose of the battery(ies) in a fire. They may explode. Check with local waste management codes for special disposal instructions.
3. Do not open or mutilate the battery(ies). Released electrolyte is corrosive and may cause burns or injury to the eyes or skin. The electrolyte may be toxic if swallowed.
4. Exercise care in handling batteries in order not to short the battery to conductive materials such as rings, bracelets, and keys. The battery and/or conductor may overheat and cause burns.
5. Charge the battery(ies) provided with or identified for use with this product only in accordance with the instructions and limitations specified in this manual.

WARNING:

TO PREVENT FIRE OR SHOCK HAZARD, DO NOT EXPOSE THIS PRODUCT TO RAIN OR ANY TYPE OF MOISTURE.

FCC and Other Information

If requested by the telephone company, inform them as follows:

FCC Registration No. (found on the bottom of the unit)

Ringer Equivalence 0.1B

The particular telephone line to which the equipment is connected.

This unit must not be connected to a coin operated line.

If you are on a party line, check with your local telephone company.

Ringer Equivalence No. (REN):

The REN is useful in determining the quantity of devices you may connect to your telephone line and still have all of those devices ring when your telephone number is called. In most, but not all areas, the sum of the REN's of all devices connected to one line should not exceed five (5.0). To be certain of the number of devices you may connect to your line, as determined by the REN, you should contact your local telephone company to determine the maximum REN for your calling area.

In the event terminal equipment causes harm to the telephone network, the telephone company should notify the customer, if possible, that service may be stopped.

However, where prior notice is impractical, the company may temporarily cease service providing that they:

- (a) Promptly notify the customer.
- (b) Give the customer an opportunity to correct the problem with their equipment.
- (c) Inform the customer of the right to bring a complaint to the Federal Communication Commission pursuant to procedures set out in FCC Rules and Regulations Subpart E of Part 68.

The Telephone Company may make changes in its communications facilities, equipment, operations or procedures, where such action is reasonably required in the operation of its business and is not inconsistent with the rules and regulations in FCC Part 68.

If such changes can be reasonably expected to render any customer terminal equipment incompatible with telephone company communications facilities, or require modification or alteration of such terminal equipment, or otherwise materially affect its use or performance, the customer shall be given adequate notice in writing, to allow the customer an opportunity to maintain uninterrupted service.

When programming emergency numbers and/or making test calls to emergency numbers:

1. Remain on the line and briefly explain to the dispatcher the reason for the call before hanging up.
2. Perform such activities in the off-peak hours, such as early morning hours or late evenings.

This device complies with Part 15 of the FCC Rules. Operation is subject to the following two conditions: (1) This device may not cause harmful interference, and (2) this device must accept any interference received, including interference that may cause undesired operation.

Privacy of communications may not be ensured when using this phone.

CAUTION:

Any changes or modifications not expressly approved by the party responsible for compliance could void the user's authority to operate this device.

Note:

This equipment has been tested and found to comply with the limits for a Class B digital device, pursuant to Part 15 of the FCC Rules. These limits are designed to provide reasonable protection against harmful interference in a residential installation. This equipment generates, uses, and can radiate radio frequency energy and, if not installed and used in accordance with the instructions, may cause harmful interference to radio communications. However, there is no guarantee that interference will not occur in a particular installation. If this equipment does cause harmful interference to radio or television reception, which can be determined by turning the equipment off and on, the user is encouraged to try to correct the interference by one or more of the following measures:

- Reorient or relocate the receiving antenna.
- Increase the separation between the equipment and receiver.
- Connect the equipment into an outlet on a circuit different from that to which the receiver is connected.
- Consult the dealer or an experienced radio/TV technician for help.

Some cordless telephones operate at frequencies that may cause interference to nearby TVs and VCRs. To minimize or prevent such interference, the base of the cordless telephone should not be placed near or on top of a TV or VCR. If interference is experienced, move the cordless telephone further away from the TV or VCR. This will often reduce, or eliminate, interference.

- **Environment**—do not place the unit in a room where the temperature is less than 5°C (41°F) or greater than 40°C (104°F). Allow 10 cm (4") clearance around the unit for proper ventilation. Avoid excessive smoke, dust, mechanical vibration, shock, or direct sunlight.
- **Medical**—consult the manufacturer of any personal medical devices, such as pacemakers, to determine if they are adequately shielded from external RF (radio frequency) energy. (The unit operates in the frequency range of 905MHz to 925MHz and the power output level can range from 0.001 watts to 0.1 watts.) Do not use the unit in health care facilities if any regulations posted in the area instruct you not to do so. Hospitals or health care facilities may be using equipment that could be sensitive to external RF (radio frequency) energy.
- **Routine care**—wipe the unit with a soft cloth. Do not use benzine, thinner, or any abrasive powder. When you leave the unit unused for a long period of time, unplug the AC adaptor from the outlet.
- **If there is any trouble**—disconnect the unit from the telephone line and connect a known working phone. If the known working phone operates properly, have your unit repaired by one of the authorized Panasonic Factory Service Centers. If the known working phone does not operate properly, consult your telephone company.

For product service

- Panasonic Servicenters are listed in the servicenter directory.
- Call 1-800-211-PANA(7262) for the location of an authorized servicenter.
- Panasonic's e-mail address for customer inquiries:
consumerproducts@panasonic.com
for customers in the USA or Puerto Rico ONLY

When you ship the product

- Carefully pack your unit, preferably in the original carton.
- Attach a letter, detailing the symptom, to the outside of the carton.

Symptom

- Send the unit to an authorized servicenter, prepaid and adequately insured.
- Do not send your unit to the Panasonic Consumer Electronics Company listed below or to executive or regional sales offices. These locations do not repair consumer products.

- This cordless telephone is designed for use in the United States of America. Sale or use of this product in other countries may violate local laws.
- Ce téléphone sans fil est conçu pour être utilisé aux États-Unis d'Amérique. La vente ou l'emploi de cet appareil dans certains autres pays peut constituer une infraction à la législation locale.
- Este teléfono sin cordón fue elaborado para uso en los Estados Unidos de América. La venta o el empleo de este producto en ciertos países puede constituir violación de la legislación local.
- このコードレス電話機は、日本国外での使用を目的として設計されており、日本国内での使用は法律違反となります。従って、当社では日本国内においては原則として修理などのサービスは致しかねます。

Panasonic Consumer Electronics Company,
Division of Matsushita Electric Corporation of America
One Panasonic Way, Secaucus, New Jersey 07094

Panasonic Sales Company,
Division of Matsushita Electric of Puerto Rico, Inc.
Ave. 65 de Infantería, Km. 9.5, San Gabriel Industrial Park
Carolina, Puerto Rico 00985